



ST. ANNE'S COLLEGE OF ENGINEERING AND TECHNOLOGY

(Approved by AICTE, New Delhi. Affiliated to Anna University, Chennai)
ANGUCHETTYPALAYAM, PANRUTI – 607 106.

EE 8701 - High Voltage Engineering

By

Mr. A.SUNDARA PANDIYAN, AP/EEE

UNIT-I**OVER VOLTAGES IN ELECTRICAL POWER SYSTEMS****PART A****1. What are the chief causes of over voltages in electric power system?(CO1-L1-JUNE2014)**

- 1) Lightning over voltages (Natural causes)
- 2) Switching over voltages (system oriented causes)

2. How are switching over voltages originated in a power system? (CO1-L1-JUNE2014)

Switching overvoltages originate in the system itself by the connection and disconnection of circuit breaker contacts or due to initiation or interruption of faults.

3. What are the techniques to be adopted for controlling the switching over voltages? (CO1-L1-JUNE2014)

- a) Installation of shunt reactors.
- b) Use of pre insertion resistor.
- c) Synchronous reclosing and simultaneous operation of CB at both end.

4. What is a surge arrester? (CO1-L1-JUNE2014)

.Surge arrester is a revolutionary advanced surge protective device for power system. It is constructed by a series connection of zinc oxide elements having a highly non linear resistance.

5. What are the causes of power frequency over voltages? (CO1-L1-JUNE2014)

The causes for power frequency and harmonic over voltages in EHV and UHV systems are:

Sudden load reflection (loss of loads)

- a) Disconnection of inductive loads or connection of capacitive loads.
- b) Ferranti effect.
- c) Unsymmetrical faults.
- d) Saturation in transformers, etc,
- e) Tap charging operations.

6. What are the causes of over voltages in power system? (CO1-L1-JUNE2014)

The causes of over voltages in power system may be internal cause or external cause. Internal causes of over voltages are

- a) Switching Transients
- b) Arcing ground
- c) Insulation failure
- d) Resonance

External cause for over voltages are Lightning.

7. What is Back Flashover? (CO1-L1-JUNE2014)

Some times when a direct lightning stroke occurs on tower if the tower footing resistance is considerable, the potential of the tower rises to a large value, in view of the huge lightning stroke current, steeply with respect to the line and consequently

8. What is insulation co-ordination? (CO1-L1-JUNE2014)

Insulation co-ordination means the correlation of the insulation of various equipments in a power system to be insulation of protective devices used for the protection of those equipments against over voltage.

9. Name the sources of switching surges. (CO1-L1-JUNE2014)

- a) Opening and closing of switchgears.
- b) In circuit breaker operation, switching surges with a high rate of rise voltage may cause repeated restriking of the arc between the contacts of the CB.
- c) High natural frequencies of the system.
- d) Damped normal frequency voltage components.
- e) Restriking and recovery voltage with successive reflected waves from terminations.

10. What is meant by switching surges? Mention the approximate magnitude of switching surges and their frequency. (CO1-L1-JUNE2014)

The switching voltage surges, occur during and closing of unload EHV Ac lines breaking inductive loads, breaking capacitive loads etc.

The switching voltage surges are of comparatively longer duration 2500 μ s lower rate of rise.

The peak value of switching surge is expressed in terms of switching over voltage factor.

Switching surges can be of the order 2 to 3.3 pu and will have the magnitudes of the order 1200 kV to 2000 kV.

11. What is Thunder storm days? (CO1-L1-JUNE2014)

Thunder storm days (TD) (is known as the IsoKeraunic level) is defined as the number of days in a year when thunder is heard or recorded in a particular location,

12. What are the techniques to be adopted for controlling the switching over voltages? (CO1-L1-JUNE2014)

- a) Installation of shunt reactors.
- b) Use of pre insertion resistor.
- c) Synchronous reclosing and simultaneous operation of CB at both end.
- g) Use of surge arrester and elimination of trapped charges by line shunting after opening by means of earthing switch.
- h) Use of surge absorber or resistance switching.

13. What are ground rods? (CO1-L1-JUNE2014)

Additional rods provided driven into the ground near the tower footing and connected to the tower footing to reduce the tower footing resistance [15 mm dia, 3.0 m long, 10 to 16 rods]

PART B

1. Show the charge distribution pattern in the cloud following Wilson and Simpson theory.
(CO1-L1-JUNE2014)

LIGHTNING PHENOMENON

Lightning phenomenon is a peak discharge in which charge accumulated in the clouds discharges into a neighboring cloud or to the ground.

The charge discharges, is very large, perhaps 10 km or more..

Charge Formation in the Clouds

During thunderstorms, positive and negative charges become separated by the heavy air currents with ice crystals in the upper part and rain in the lower parts of the cloud.

This charge separation depends on the

- ✓ Height of the clouds = 200 to 10,000 m,
- ✓ Distance of the clouds = 300 to 2000 m.
- ✓ Charge inside the cloud = 1 to 100 C.
- ✓ Potential of the cloud = 107 to 108 V with field gradients ranging from 100 V/cm within the cloud to as high as 10 kV/cm at the initial discharge point.
- ✓ The energy associated with the
- ✓ cloud discharges = 250 kWh.

Generally it is known that the upper regions of the cloud and local region near the base are usually positively charged, whereas the lower region and the base are negatively charged.

The maximum gradient reached at the ground level due to a charged cloud may be as high as 300 V/cm, while the fair weather gradients are about 1 V/cm.

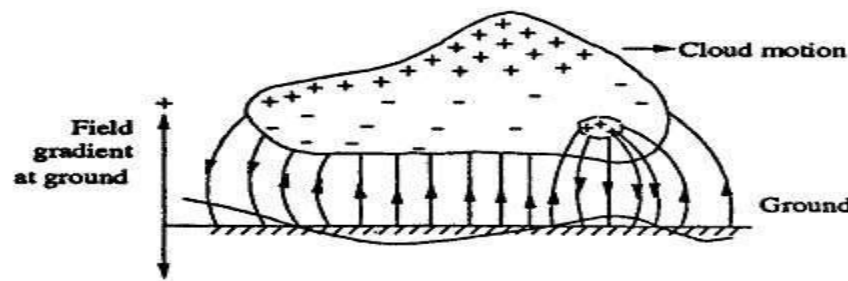

Theories based on lightning:

Simpson's Theory:

According to the Simpson's theory there are three essential regions in the cloud to be considered for charge formation.

- ✓ Below region A, air currents travel Ground Cloud motion Field gradient at ground above 800 cm/s, and no raindrops fall through.
- ✓ In region A, air velocity is high enough to break the falling raindrops causing a positive charge spray in the cloud and negative charge in the air
- ✓ As the spray is blown upwards, but as the velocity of air decreases, the positively charged water drops recombine with the larger drops and fall again Thus region A, becomes positively charged,
- ✓ In region B above it, becomes negatively charged by air currents.
- ✓ In the region C the temperature is low (below freezing point) and only ice crystals exist so the impact of air on these crystals makes them negatively charged, thus the distribution of the charge within the cloud becomes as shown in Fig.

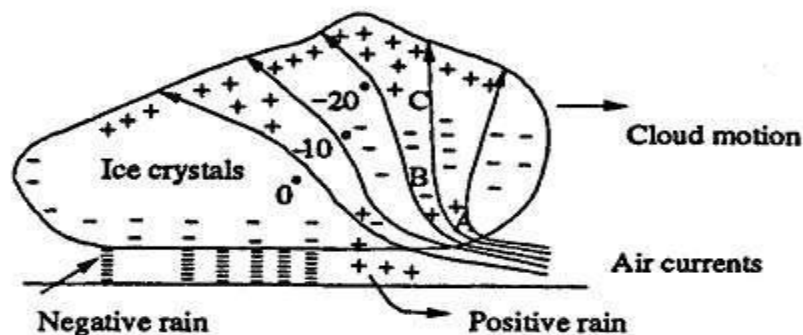

Cloud Model According To Simpson's Theory

Reynolds and Mason Theory:

- ✓ Reynolds and Mason proposed modification, according to which the thunder clouds are developed at heights 1 to 2 km above the ground level and may extend up to 12 to 14 km above the ground.
- ✓ For thunder clouds and charge formation air currents, moisture and specific temperature range are required and the air currents controlled by the temperature gradient move upwards carrying moisture and water droplets.

- ✓ The temperature is 0°C and water droplets do not freeze at about 4 km from the ground and may reach -50°C and they freeze below -40°C only as solid particles on which crystalline ice patterns develop and grow at about 12 km height.
- ✓ Thus in clouds, the effective freezing temperature range is around -30°C to -40°C .
- ✓ When such freezing occurs, the crystals grow into large masses and due to their weight and gravitational force start moving downwards. Thus, a thunder cloud consists of super cooled water droplets moving upwards and large hail stones moving downwards.
- ✓ When the process of cooling extends to inside warmer water in the core, it expands, thereby splintering and spraying the frozen ice shell. The splinters being fine in size are moved up by the air currents and carry a net positive charge to the upper region of the cloud.
- ✓ The hail stones that travel onwards carry an equivalent Negative rain Positive rain Air currents Cloud motion Ice crystals negative charge to the lower regions of the cloud and thus negative charge builds up in the bottom side of the cloud.
- ✓ According to Mason, the ice splinters should carry only positive charge upwards. Therefore, the lower portion which is warmer will have a net negative charge density, and hence the upper portion, i.e. cooler region will have a net positive charge density.
- ✓ According to the Reynold's theory, which is based on experimental results, the hail packets get negatively charged when impinged upon by warmer ice crystals.
- ✓ When the temperature conditions are reversed, the charging polarity reverses. However, the extent of the charging and consequently the rate of charge generation were found to disagree with the practical observations relating to thunder clouds. This type of phenomenon also occurs in thunder clouds.

2.Explain the mechanism of Lightning with neat diagrams. (CO1-L1-JUNE2014)

Mechanism of Lightning Stroke

- ✓ Lightning phenomenon is the discharge of the cloud to the ground. The cloud and the ground form two plates of a gigantic capacitor and the dielectric medium is air. Since the lower part of the cloud is negatively charged, the earth is positively charged by induction.
- ✓ Lightning discharge will require the puncture of the air between the cloud and the earth. For breakdown of air at steady condition the electric field required is 30 kV/cm peak. But in a cloud where the moisture content in the air is large and also because of the high altitude (lower pressure) it is seen that for breakdown of air the electric field required is

only 10 kV/cm. After a gradient of approximately 10 kV/cm is set up in the cloud, the air surrounding gets ionized.

- ✓ At this a streamer starts from the cloud towards the earth which cannot be detected with the naked eye; only a spot travelling is detected. The current in the streamer is of the order of 100 amperes and the speed of the streamer is 0.16 m/ μ sec. This streamer is known as pilot streamer because this leads to the lightning phenomenon.
- ✓ Depending upon the state of ionization of the air surrounding the streamer, it is branched to several paths and this is known as stepped leader . The leader steps are of the order of 50 m in length and are accomplished in about a microsecond.
- ✓ The charge is brought from the cloud through the already ionized path to these pauses. The air surrounding these pauses is again ionized and the leader in this way reaches the earth .Once the stepped leader has made contact with the earth it is believed that a power return stroke moves very fast up towards the cloud through the already ionized path by the leader.
- ✓ This streamer is very intense where the current varies between 1000 amps and 200,000 amps and the speed is about 10% that of light and the -ve charge of the cloud is being neutralized by the positive induced charge on the earth. It is this instant which gives rise to lightning flash which we observe with our naked eye.
- ✓ There may be another cell of charges in the cloud near the neutralized charged cell. This charged cell will try to neutralize through this ionised path. This streamer is known as dart leader . The velocity of the dart leader is about 3% of the velocity of light.
- ✓ The effect of the dart leader is much more severe than that of the return stroke. The discharge current in the return streamer is relatively very large but as it lasts only for a few microseconds the energy contained in the streamer is small and hence this streamer is known as cold lightning stroke.
- ✓ Dart leader is known as hot lightning stroke because even though the current in this leader is relatively smaller but it lasts for some milliseconds and therefore the energy contained in this leader is relatively larger.
- ✓ It is found that each thunder cloud may contain as many as 40 charged cells and a heavy lightning stroke may occur. This is known as multiple stroke.

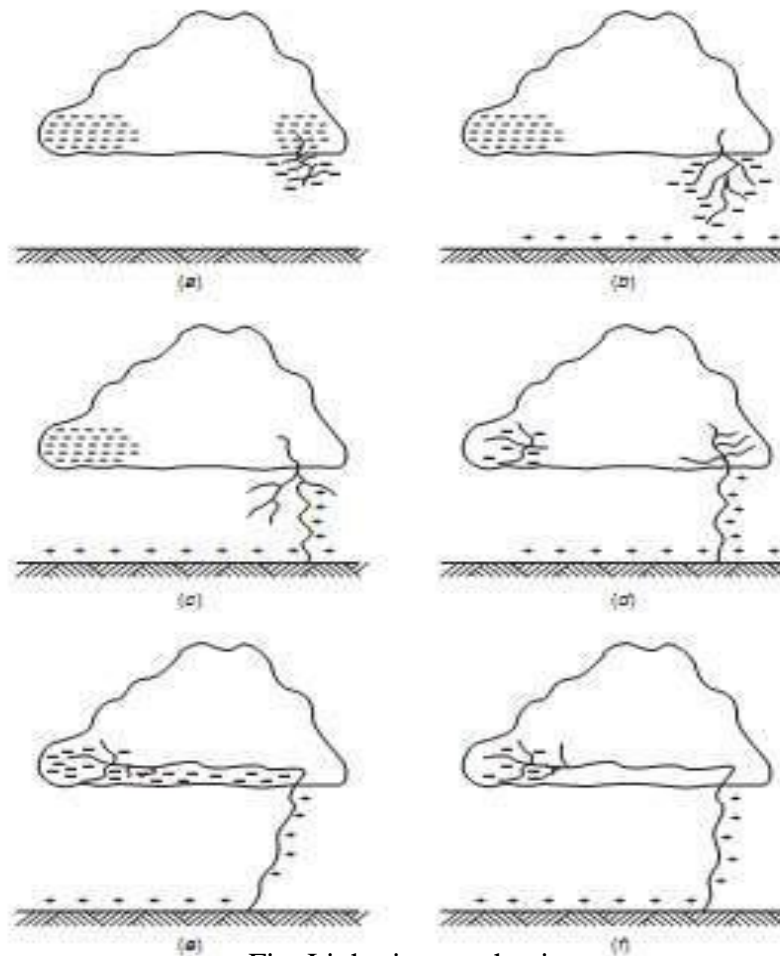

Fig. Lightning mechanism

3.Explain the mathematical model for lightning. (CO1-L1-JUNE2014)

Mathematical Model for Lightning

- ✓ During the charge formation process, the cloud may be considered to be a non-conductor. Hence, various potentials may be assumed at different parts of the cloud.
- ✓ If the charging process is continued, it is probable that the gradient at certain parts of the charged region exceeds the breakdown strength of the air or moist air in the cloud. Hence, local breakdown takes place within the cloud.
- ✓ This local discharge may finally lead to a situation wherein a large reservoir of charges involving a considerable mass of cloud hangs over the ground, with the air between the cloud and the ground as a dielectric.

- ✓ When a streamer discharge occurs to ground by first a leader stroke, followed by main strokes with considerable currents flowing, the lightning stroke maybe thought to be a current source of value Z/Q with source impedance Z_0 discharging to earth. If the stroke strikes an object of impedance Z , the voltage built across it may be taken as

$$\begin{aligned}
 V &= I Z \\
 &= I_0 \frac{Z Z_0}{Z + Z_0} \\
 &= I_0 \frac{Z}{1 + \frac{Z}{Z_0}}
 \end{aligned}$$

- ✓ The source impedance of the lightning channels are not known exactly, but it is estimated to be about 1000 to 3000 Ω . Therefore, the value Z/Z_0 will usually be less than 0.1 and hence can be neglected. Hence, the voltage rise of lines, etc. may be taken to be approximately $V / I_0 Z$, where I_0 is the lightning stroke current and Z the line surge impedance
- ✓ If a lightning stroke current as low as 10,000 A strikes a line of 400 Ω surge impedance, it may cause an overvoltage of 4000 kV. This is a heavy overvoltage and causes immediate flashover of the line conductor through its insulator strings.
- ✓ In case a direct stroke occurs over the top of an unshielded transmission line, the current wave tries to divide into two branches and travel on either side of the line.

4.Explain the sources and characteristics of switching surges(CO1-L1-JUNE2014

OVERVOLTAGE DUE TO SWITCHING SURGES,

Origin of Switching Surges

- ✓ The making and breaking of electric circuits with switchgear may result in abnormal over voltages in power systems having large inductances and capacitances. The over voltages may go as high as six times the normal power frequency voltage.
- ✓ In circuit breaking operation, switching surges with a high rate of rise of voltage may cause repeated restriking of the arc between the contacts of a circuit breaker, there by using destruction of the circuit breaker contacts.

- ✓ The switching surges may include high natural frequencies of the system, a damped normal frequency voltage component, or the restriking and recovery voltage of the system with successive reflected waves from terminations.

Characteristics of Switching Surges

The wave shapes of switching surges are quite different and may have origin from any of the following sources.

- (i) De-energizing of transmission lines, cables, shunt capacitor, banks, etc.
- (ii) Disconnection of unloaded transformers, reactors, etc.
- (iii) Energization or reclosing of lines and reactive loads,
- (iv) Sudden switching off of loads.
- (v) Short circuits and fault clearances.
- (vi) Resonance phenomenon like ferro-resonance, arcing grounds, etc. From the figures of the switching surges it is clear that the over voltages are irregular (oscillatory or unipolar) and can be of high frequency or power frequency with its harmonics. The relative magnitudes of the over voltages may be about 2.4 p.u. in the case of transformer energizing and 1.4 to 2.0 p.u. in switching transmission lines.

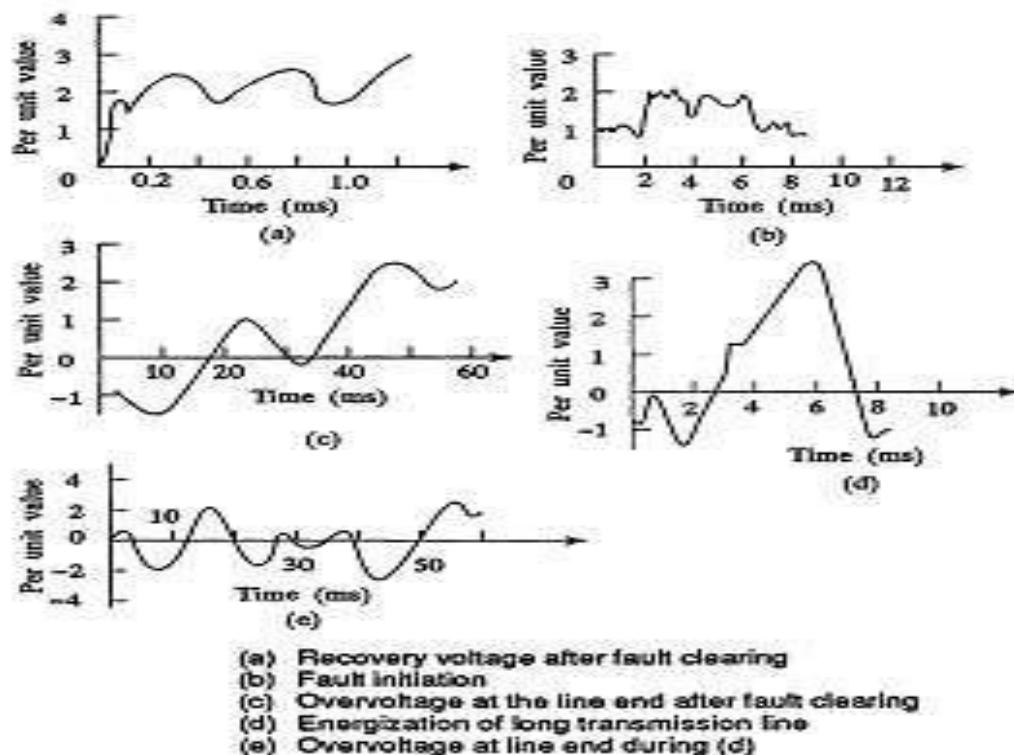

Switching Over voltages in EHV and UHV Systems

- ✓ The insulation has the lowest strength for switching surges with regard to long airgaps. Further, switching over voltages is relatively higher magnitudes as compared to the lightning over voltages for UHV systems.
- ✓ Over voltages are generated in EHV systems when there is a sudden release of internal energy stored either in the electrostatic form (in the capacitance) or in the electromagnetic form (in the inductance). The different situations under which this happens are summarized as
 - (i) Interruption of low inductive currents (current chopping) by high speed circuit breakers. This occurs when the transformers or reactors are switched off
 - (ii) Interruption of small capacitive currents, such as switching off of unloaded lines etc.
 - (iii) ferro-resonance condition This may occur when poles of a circuit breaker do not close simultaneously
 - (iv) energization of long EHV or UHV lines.

Transient over voltages in the above cases can be of the order of 2.0 to 3.3 p.u. and will have magnitudes of the order of 1200 kV to 2000 kV on 750 kV systems. The duration of these over voltages varies from 1 to 10 ms depending on the circuit parameters. It is seen that these are of comparable magnitude or are even higher than those that occur due to lightning. Sometimes the over voltages may last for several cycles.

The other situations of switching that give rise to switching over voltages of shorter duration (0.5 to 5 ms) and lower magnitudes (2.0 to 2.5 p.u.) are:

- (a) single pole closing of circuit breaker
- (b) interruption of fault current when the L-G or L-L fault is cleared
- (c) resistance switching used in circuit breakers
- (d) switching lines terminated by transformers
- (e) series capacitor compensated lines
- (f) Sparking of the surge diverter located at the receiving end of the line to limit the lightning Over voltages

The over voltages due to the above conditions are studied or calculated from:

- (a) mathematical modeling of a system using digital computers
- (b) scale modeling using transient network analyzers
- (c) By conducting field tests to determine the expected maximum amplitude of the over voltages and their duration at different points on the line.

The main factors that are investigated in the above studies are:

- (i) the effect of line parameters, series capacitors and shunt reactors on the magnitude and duration of the transients
- (ii) the damping factors needed to reduce the magnitude of over voltages
- (iii) the effect of single pole closing, restriking and switching with series resistors or circuit breakers on the over voltages, and
- (iv) The lightning arrester spark over characteristics.

It is necessary in EHV and UHV systems to control the switching surges to a safe value of less than 2.5 p.u. or preferably to 2.0 p.u. or even less. The measures taken to control or reduce the over voltages are

- (i) one step or multi-step energisation of lines by pre insertion of resistors,
- (ii) phase controlled closing of circuit breakers with proper sensors,
- (iii) drainage of trapped charges on long lines before the reclosing of the lines, and
- (iii) limiting the over voltages by using surge diverters.

5. What are causes of power frequency over voltages in power system? Explain them in detail. (CO1-L1-JUNE2014)

The power frequency over voltages occur in large power systems and they are of much concern in EHV systems, i.e. systems of 400 kV and above. The main causes for power frequency and its harmonic over voltages are

- (a) sudden loss of loads,
- (b) disconnection of inductive loads or connection of capacitive loads,
- (c) Ferranti effect, unsymmetrical faults, and
- (d) saturation in transformers, etc.

- ✓ Over voltages of power frequency harmonics and voltages with frequencies nearer to the operating frequency are caused during tap changing operations, by magnetic or ferro-resonance phenomenon in large power transformers and by resonating over voltages due to series capacitors with shunts reactors or transformers.
- ✓ The duration of these over voltages may be from one to two cycles to a few seconds depending on the overvoltage protection employed in the system.

$$I_C = j\omega CV_1 = \frac{V_1}{X_C}$$

$$\text{and the voltage } V_2 = V_1 \left[1 - \frac{X_L}{2X_C} \right]$$

where, X_L = line inductive reactance, and
 X_C = line capacitive reactance.

a) Sudden Load Rejection

Sudden load rejection on large power systems causes the speeding up of generator prime movers. The speed governors and automatic voltage regulators will intervene to restore normal conditions. But initially both the frequency and voltage increase. The approximate voltage rise, neglecting losses, etc. may be taken as

$$v = \frac{f}{f_0} E' \left[\left(1 - \frac{f}{f_0} \right) \frac{x_s}{x_c} \right]$$

where X_s is the reactance of the generator (« the sum of the transient reactance of the generator and the transformer), X_c is the capacitive reactance of the line at open end at increased frequency, if the voltage generated before the over-speeding and load rejection, is the instantaneous increased frequency, and f_0 is the normal frequency.

(b) Ferranti Effect

Long uncompensated transmission lines exhibit voltage rise at the receiving end. The voltage rise at the receiving end V_2 is approximately given by considering that the line capacitance is concentrated at the middle of the line, under open circuit conditions at the receiving end, the line charging current

$$V_2 = \frac{V_1}{\cos \beta l}$$

where,

V_1 = sending end voltage,

l = length of the line,

β = phase constant of the line

$$\approx \left[\frac{(R + j\omega L)(G + j\omega C)}{LC} \right]^{1/2}$$

≈ about 6° per 100 km line at 50 Hz frequency.

$R, L, G,$ and C are as defined in Sec. 8.1.5, and

ω = angular frequency for a line shown in Fig. 8.17.

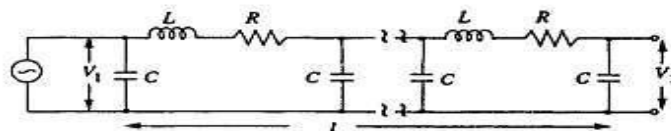

L, R and C — Inductance, resistance and capacitance per unit length of the line
 l — Length of the line

(c) Ground Faults and Their Effects

Single line to ground faults cause rise in voltages in other healthy phases. Usually, with solidly grounded systems, the increases in voltage (phase to ground value) will be less than the line-to-line voltage.

$$\frac{X_0}{X_1} \leq 3.0 \text{ and } \frac{R_0}{X_1} \leq 1.0$$

With effectively grounded systems, i.e. with (where, R_Q and X_Q are zero sequence resistance and reactance and X] is the positive sequence reactance of the system), the rise in voltage of the healthy phases does not usually exceed 1.4 per unit.

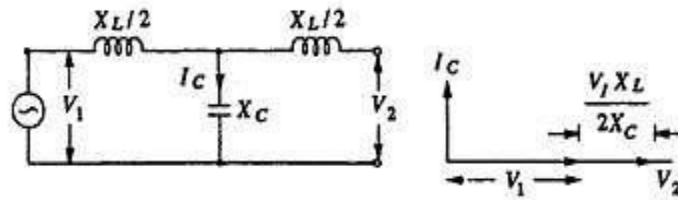

(e) Saturation Effects

- ✓ When voltages above the rated value are applied to transformers, their magnetizing currents (no load currents also) increase rapidly and may be about the full rated current for 50% overvoltage. These magnetizing currents are not sinusoidal in nature but are of a peaky waveform.
- ✓ The third, fifth, and seventh harmonic contents may be 65%, 35%, and 25% of the exciting current of the fundamental frequency corresponding to an overvoltage of 1.2 p.u. For third and its multiple harmonics, zero sequence impedance values are effective, and delta connected windings suppress them.
- ✓ But the shunt connected capacitors and line capacitances can form resonant circuits and cause high third harmonic over voltages. When such over voltages are added, the voltage rise in the lines may be significant.
- ✓ For higher harmonics a series resonance between the transformer inductance and the line capacitance can occur which may produce even higher voltages.

6.Explain the control methods of over voltages due to switching. (CO1-L1-JUNE2014)

Control of Over voltages Due to Switching

The over voltages due to switching and power frequency may be controlled by

- (a).Energization of transmission lines in one or more steps by inserting resistances and withdrawing them afterwards,
- (b).Phase controlled closing of circuit breakers,
- (c).Drainage of trapped charges before reclosing,
- (d).Use of shunt reactors, and
- (e) .Limiting switching surges by suitable surge diverters.

(a) Insertion of Resistors

- ✓ It is normal and a common practice to insert resistances in series with circuit breaker contacts when switching on but short circuiting them after a few cycles. This will reduce the transients occurring due to switching. The voltage step applied is first reduced to $Z_0/(R + Z_0)$ per unit where Z_0 is the surge impedance of the line. It is reflected from the far end unchanged and again reflected back from the near end with reflection factor $(R - Z_0)/(R + Z_0)$ per unit
- ✓ If $R = Z_0$, there is no reflection from the far end. The applied step at the first instance is only 0.5 per unit. When the resistor is short circuited, a voltage step equal to the instantaneous voltage drop enters the line. If the resistor is kept for a duration larger than 5ms (for 50 Hz sine wave = 1/4 cycle duration), it can be shown from successive reflections and transmissions, that the overvoltage may reach as high as 1.2 p.u. for a line length of 500 km.
- ✓ But for conventional opening of the breaker, the resistors have too high an ohmic value to be effective for resistance closing. Therefore, pre-insertion of suitable value resistors in practice is done to limit the overvoltage to less than 2.0 to 2.5 p.u. Normal time of insertion is 6 to 10 m s.

(b) Phase Controlled Switching

Over voltages can be avoided by controlling the exact instances of the closing of the three phases separately. But this necessitates the use of complicated controlling equipment and therefore is not adopted.

(c) Drainage of Trapped Charge

- ✓ When lines are suddenly switching off, "electric charge" may be left on capacitors and line conductors. This charge will normally leak through the leakage path of the insulators, etc. Conventional potential transformers (magnetic) may also help the drainage of the charge.
- ✓ An effective way to reduce the trapped charges during the lead time before reclosing is by temporary insertion of resistors to ground or in series with shunt reactors and removing before the closure of the switches.

(d) Shunt Reactors:

Normally all EHV lines will have shunt reactors to limit the voltage rise due to the Ferranti effect. They also help in reducing surges caused due to sudden energizing. However, shunt reactors cannot drain the trapped charge but will give rise to oscillations with the capacitance of the system. Since the compensation given by the reactors will be less than 100%, the frequency of oscillation will be less than the power frequency and over voltages produced may be as high as 1.2 p.u. Resistors in series with these reactors will suppress the oscillations and limit the over voltages.

7.What are the different methods employed for lightning protection of overhead lines?

Over voltages due to lightning strokes can be avoided or minimized in practice by

- (a) shielding the overhead lines by using ground wires above the phase wires,
- (b) using ground rods and counter-poise wires, and
- (c) including protective devices like expulsion gaps, protector tubes on the lines, and surge diverters at the line terminations and substations.

(a) Lightning Protection Using Shielded Wires or Ground Wires

- ✓ Ground wire is a conductor run parallel to the main conductor of the transmission line supported on the same tower and earthed at every equally and regularly spaced towers. It is run above the main conductor of the line. The ground wire shields the transmission line conductor from induced charges, from clouds as well as from a lightning discharge.
- ✓ The mechanism by which the line is protected may be explained as follows. If a positively charged cloud is assumed to be above the line, it induces a negative charge on the portion below it, of the transmission line. With the ground wire present, both the ground wire and the line conductor get the induced charge.
- ✓ But the ground wire is earthed at regular intervals, and as such the induced charge is drained to the earth potential only; the potential difference between the ground wire and the cloud and that between the ground wire and the transmission line wire will be in the inverse ratio of their respective capacitances [assuming the cloud to be a perfect conductor and the atmospheric medium (air) a dielectric].

The shielding angle :

- ✓ As the ground wire is nearer to the line wire, the induced charge on it will be much less and hence the potential rise will be quite small. The effective protection or shielding given by the ground wire depends on the height of the ground wire above the ground and the protection or shielding angle θ_s (usually 30°)
- ✓ The shielding angle $65^\circ < \theta_s < 30^\circ$ was considered adequate for tower heights of 30 m or less. The shielding wires may be one or more depending on the type of the towers used. But for EHV lines, the tower heights may be up to 50 m, and the lightning strokes sometimes occur directly to the line wires as shown. The present trend in fixing the tower heights and shielding angles is by considering the "flash over rates" and failure probabilities.

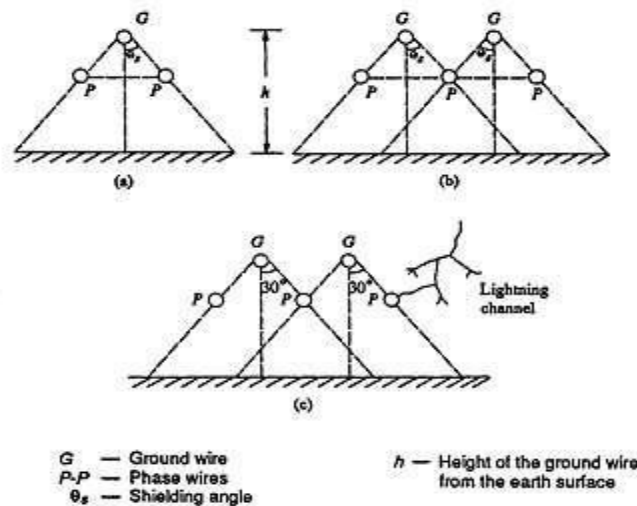

(b) Protection Using Ground Rods and Counter-Poise Wires

When a line is shielded, the lightning strikes either the tower or the ground wire. The path for drainage of the charge and lightning current is (a) through the tower frame to ground, through the ground line in opposite directions from the point of striking. Thus the ground wire reduces the instantaneous potential to which the tower top rises considerably, as the current path is in three directions. The instantaneous potential to which tower top can rise is

$$V_T = \frac{I_0 Z_T}{\left(1 + \frac{Z_T}{Z_S}\right)}$$

where,

Z_T = surge impedance of the tower, and

Z_S = surge impedance of the ground wire.

If the surge impedance of the tower, which is the effective tower footing resistance, is reduced, the surge voltage developed is also reduced considerably. This is accomplished by providing driven ground rods and counter-poise wires connected to tower legs at the tower foundation. Lightning channel Ground rods are a number of rods about 15 mm diameter and 2.5 to 3 m long driven into the ground. In hard soils the rods may be much longer and can be driven to a depth of, say, 50 m.

They are usually made of galvanized iron or copper bearing steel. The spacings of the rods, the number of rods, and the depth to which they are driven depend on the desired tower footing resistance. With 10 rods of 4 m long and spaced 5 m apart, connected to the legs of the tower, the dynamic or effective resistance may be reduced to 10 ft.

The above effect is alternatively achieved by using counter-poise wires. Counter-poise wires are wires buried in the ground at a depth of 0.5 to 1.0 m, running parallel to the transmission line conductors and connected to the tower legs these wires may be 50 to 100 m long.

These are found to be more effective than driven rods and the surge impedance of the tower may be reduced to as low as 25 Ω . The depth does not materially affect the resistance of the counter-poise, and it is only necessary to bury it to a depth enough to prevent theft. It is desirable to use a larger number of parallel wires than a single wire. But it is difficult to lay counter-poise wires compared to ground or driven rods.

(c) Protective Devices

In regions where lightning strokes are intensive or heavy, the overhead lines within these zones are fitted with shunt protected devices. On the line itself two devices known as expulsion gaps and protector tubes are used. Line terminations, junctions of lines, and sub-stations are usually fitted with surge diverters.

(i) Expulsion gaps

Expulsion gap is a device which consists of a spark gap together with an arc quenching device which extinguishes the current arc when the gaps break over due to over-voltages. A typical such arrangement is shown in Fig. 8.20a. This essentially consists of a rod gap in air in series with a second gap enclosed within a fibre tube. In the event of an overvoltage, both the spark gaps breakdown simultaneously. The current due to the overvoltage is limited only by the tower footing resistance and the surge impedance of the ground wires. The internal arc in the fibre tube due to lightning current vaporizes a small portion of the fibre material.

The gas thus produced, being a mixture of water vapour and the decomposed fibre product, drive away the arc products and ionized air. When the follow-on power frequency current passes

through zero value, the arc is extinguished and the path becomes open circuited. Meanwhile the insulation recovers its dielectric strength, and the normal conditions are established. The lightning and follow-up power frequency currents together can last for 2 to 3 half cycles only. Therefore, generally no disturbance in the network is produced. For 132 or 220 kV lines, the maximum current rating may be about 7,500 A.

(ii) Protector tubes

A protector tube is similar to the expulsion gap in, construction and principle. It also consists of a rod or spark gap in air formed by the line conductor and its high voltage terminal. It is mounted underneath the line conductor on a tower. The arrangement is shown in Fig. . The hollow gap in the expulsion tube is replaced by a nonlinear element which offers a very high impedance at low currents but has low impedance for high or lightning currents. When an overvoltage occurs and the spark gap breaks

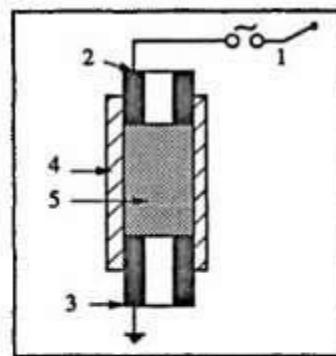

1. External series gap
2. Upper electrode
3. Ground electrode
4. Fibre tube
5. Hollow space

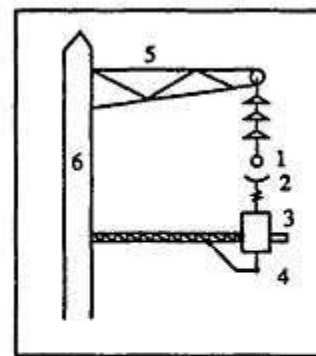

1. Line conductor on string insulator
2. Series gap
3. Protector tube
4. Ground connection
5. Cross arm
6. Tower body

down, the current is limited both by its own resistance and the tower footing resistance. The overvoltage on the line is reduced to the voltage drop across the protector tube. After the surge current is diverted and discharged to the ground, the follow-on normal power frequency current will be limited by its high resistance. After the current zero of power frequency, the spark gap recovers the insulation strength quickly. Usually, the flashover voltage of the protector tube is less than that of the line insulation, and hence it can discharge the lightning overvoltage effectively.

(iv) Rod gaps

- ✓ A much simpler and effective protective device is a rod-gap. However, it does not meet the complete requirement. The spark over voltage of a rod gap depends on the atmospheric conditions. There is no current limiting device provided so as to limit the current after spark over, and hence a series resistance is often used.
- ✓ Without a series resistance, the sparking current may be very high and the applied impulse voltage suddenly collapses to zero thus creating a steep step voltage, which sometimes proves to be very dangerous to the apparatus to be protected, such as transformer or the machine windings. Nevertheless, rod gaps do provide efficient protection where thunderstorm activity is less and the lines are protected by ground wires.

(v) Surge diverters or lightning arresters

- ✓ Surge diverters or lightning arresters are devices used at sub-stations and at line terminations to discharge the lightning over voltages and short duration switching surges. These are usually mounted at the line end at the nearest point to the sub-station.
- ✓ They have a flashover voltage power than that of any other insulation or apparatus at the sub-station. These are capable of discharging 10 to 20 kA of long duration surges (8/20 p. s) and 100 to 250 kA of the short duration surge currents (1/5\JL s)

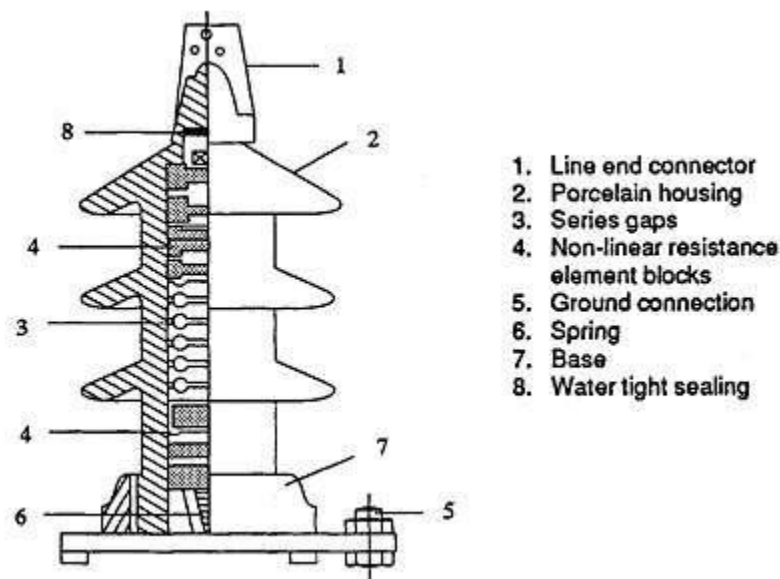

- ✓ These are non-linear resistors in series with spark gaps which act as fast switches. A typical surge diverter or lightning arrester is shown in Fig. and its characteristics are given in Fig. A number of non-linear resistor elements made of silicon carbide are stacked one over the other into two or three sections.

- ✓ They are usually separated by spark gaps. The entire assembly is housed in a porcelain water-tight housing. When a surge voltage is applied to the surge diverter, it breaks down giving the discharge current I and maintains a voltage V across it. The lighter designs operate for smaller duration of currents, while the heavy duty surge diverters with assisted or active gaps are designed for high currents and long duration surges.
- ✓ The lighter design arresters can interrupt 100 to 300 A of power frequency follow-on current and about 5000 A of surge currents. If the current is to be more and has to be exceeded, the number of series elements has to be increased or some other method to limit the current has to be used.
- ✓ In heavy duty arresters, the gaps are so arranged that the arc burns in the magnetic field of the coils excited by power frequency follow-on currents. During lightning discharges, a high voltage is induced in the coil by the steep front of the surge, and sparking occurs in an auxiliary gap. For power frequency follow-on currents, the auxiliary gap is extinguished, as sufficient voltage will not be present across the auxiliary gap to maintain an arc.
- ✓ The main gap arcs occur in the magnetic field of the coils. The magnetic field, aided by the horn shaped main gap electrodes, elongates the arc and quenches it rapidly. The follow-on current is limited by the voltage drop across the arc and the resistance element.
- ✓ During surge discharge the lightning protective level becomes low. Sometimes, it is possible to limit the power frequency and other over voltages after a certain number of cycles using surge diverters. The permissible voltage and duration depend on the thermal capacity of the diverter. The rated diverter voltage is normally chosen so that it is not less than the power frequency overvoltage expected (line to ground) at the point of installation, under any faulty or abnormal operating condition.

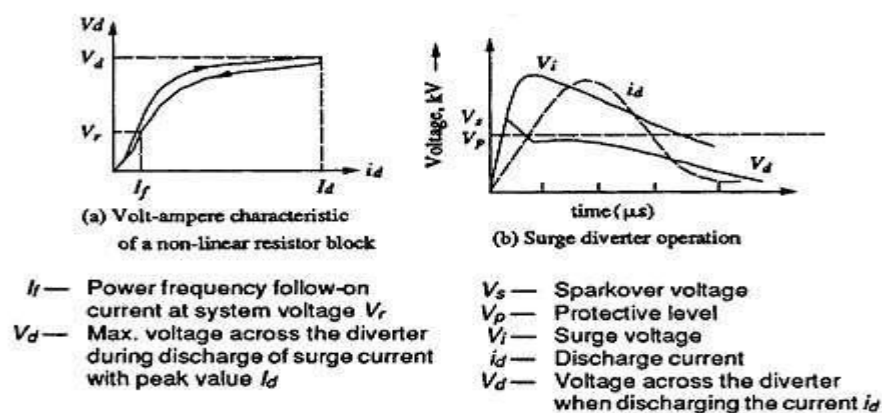

8.Explain corona and its effect on power system. (CO1-L1-JUNE2014)

Corona, also known as partial discharge, is a type of localized emission resulting from transient gaseous ionization in an insulation system when the voltage stress, i.e., voltage gradient, exceeds a critical value. The ionization is usually localized over only a portion of the distance between the electrodes of the system. Corona can occur within voids in insulators as well as at the conductor/insulator interface.

Corona Inception

Corona inception voltage is the lowest voltage at which continuous corona of specified pulse amplitude occurs as the applied voltage is gradually increased. Corona inception voltage decreases as the frequency of the applied voltage increases. Corona can occur in applications as low as 300V.

Corona Extinction

Corona extinction voltage is the highest voltage at which continuous corona of specified pulse amplitude no longer occurs as the applied voltage is gradually decreased from above the corona inception value. Thus, once corona starts, the voltage must be decreased to get it to stop.

Corona Detection

Corona can be visible in the form of light, typically a purple glow, as corona generally consists of micro arcs. Darkening the environment can help to visualize the corona. Corona discharges in insulation systems result in voltage transients. These pulses are superimposed on the applied voltage and may be detected, which is precisely what corona detection equipment looks for. In its most basic form, the following diagram is a corona (or partial discharge) measuring system:

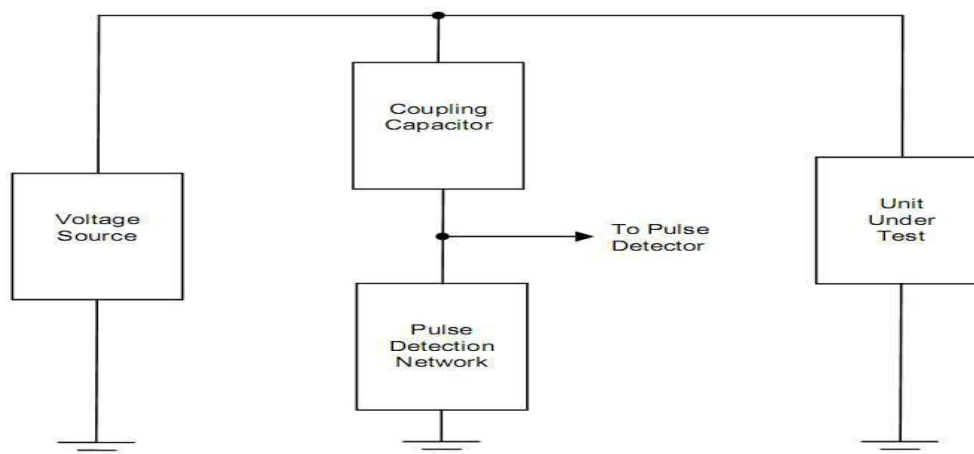

Corona Effects

The presence of corona can reduce the reliability of a system by degrading insulation. While corona is a low energy process, over long periods of time, it can substantially degrade insulators, causing a system to fail due to dielectric breakdown. The effects of corona are cumulative and permanent, and failure can occur without warning.

Corona causes:

- Light
- Ultraviolet radiation
- Sound (hissing, or cracking as caused by explosive gas expansions)
- Ozone
- Nitric and various other acids
- Salts, sometimes seen as white powder deposits
- Other chemicals, depending on the insulator material
- Mechanical erosion of surfaces by ion bombardment
- Heat (although generally very little, and primarily in the insulator)
- Carbon deposits, thereby creating a path for severe arcing

Corona Prevention

Corona can be avoided by minimizing the voltage stress and electric field gradient. This is accomplished by using utilizing good high voltage design practices, i.e., maximizing the distance between conductors that have large voltage differentials, using conductors with large radii, and avoiding parts that have sharp points or sharp edges.

Corona inception voltage can sometimes be increased by using a surface treatment, such as a semiconductor layer, high voltage putty or corona dope. Also, use a good, homogeneous insulator. Void free solids, such as properly prepared silicone and epoxy potting materials work well. If you are limited to using air as your insulator, then you are left with geometry as the critical parameter. Finally, ensure that steps are taken to reduce or eliminate unwanted voltage transients, which can cause corona to start.

UNIT II**DIELECTRIC BREAKDOWN****PART A****1. Define Gas Law. (CO2-L1-NOV2014)**

It consists of many laws. The following laws are very important.

- a) Charle's law $P \propto T$ Volume is constant
- b) Boyle's law $P \propto 1/V$ T is constant

General equation: $PV = nRT$

Where

P-pressure ; V-Volume; n-number of moles; R-molar gas constant; T-temperature.

2. What is Paschen's law? (CO2-L1-NOV2014)

$$f_2\left(\frac{V}{pd}\right) \left[\exp\left\{pd f_1\left(\frac{V}{pd}\right)\right\} - 1 \right] = 1$$

This equation shows a relationship between V and pd, and implies that the breakdown voltage varies as a product pd varies knowing the nature of functions f_1 and f_2 we can rewrite this equation

$$V = f(pd)$$

Where

P - Gas pressure f - function

d - the electrode of dp V - Voltage

3. Which insulation is used in high voltage circuit breakers of large power rating? (CO2-L1-NOV2014)

Now a day's most of all circuit breakers that are in operation use SF6 gas or vacuum as insulating medium. SF6 circuit breakers are manufactured up to the higher transmission voltage of 800 kV and current range of 63 kA and 80 kA. However it is an expensive gas and at the normal operating pressure of 6 bar it condenses at temperatures lower than 20°C.

4. What is Time lag in the breakdown of dielectrics? (CO2-L1-NOV2014)

The time that elapses between the application of the voltage to a gap sufficient to cause breakdown and actual breakdown is called time lag.

5. Define uniform and non uniform field and give examples of each. (CO2-L1-NOV2014)

In uniform field the applied field remains constant across the gap. Example: The field between the two plane electrodes.

In non uniform field the applied field varies across the gap.

The examples are coaxial cylinders, point- plane and the sphere plane gaps.

6. Define the following as applied to high voltage breakdown. (CO2-L1-NOV2014)

- a) Internal and External insulation
- b) Flashover

Internal and External insulation

Disruptive discharge voltage produces the loss of dielectric strength of insulation. It is the voltage at which the electrical stress in the insulation causes a failure which includes the collapse of voltage and passage of current.

Flashover

When discharge takes place between two electrodes in gas or liquid over a solid surface on air it is called flashover.

7. Define the following as applied to disruptive voltage. (CO2-L1-NOV2014)

- a) Flashover voltage
- b) Spark over voltage

a) Flashover

When discharge takes place between two electrodes in gas or liquid over a solid surface on air it is called flashover.

b) Spark over voltage

The voltage between two spheres on sphere gap is raised till a spark passes between two spheres. The value voltage of spark over depends upon the dielectric strength of air, size of sphere and distance between the sphere and other factors.

8. Name a few gases used as insulation medium? (CO2-L1-NOV2014)

N₂, CO₂, CC₂F₂ (Freon), SF₆ (SulphurHexa Fluoride)

9. Name the theories explaining B.D in gaseous insulation? (CO2-L1-NOV2014)

- 1) Town sends Theory
- 2) Streamer Theory.

10. What are the physical conditions governing ionization mechanism in gases dielectrics? (CO2-L1-NOV2014)

1. Pressure
2. Temperature
3. Electrode configuration
4. Nature of electrode surface
5. Availability of initial conducting particles

11. What is primary ionization? (CO2-L1-NOV2014)

Electron produced at the cathode by some external means, during its travel towards the anode due to the field applied, make collisions with neutral atoms/molecules and liberate electrons & positive ions. The liberated ions make future collisions and the process continues. The electrons and the ions constitute current. This process is called primary ionization.

12. What is secondary ionization? (CO2-L1-NOV2014)

The liberated positive ions, during the primary ionization process migrate towards cathode bombard and emit secondary electrons from the cathode.

The excited atoms/molecules, got excited during the collision of initial electrons, emit photons which bombard the cathode & emit secondary electrons

Metastable (excited particles) bombard the cathode metal surface & produce Secondary Electrons

13. Define primary ionization co-efficient .(Townsend's 1st ionization co-efficient)? (CO2-L1-NOV2014)

The average number of ionizing collisions made by an electron per centimeter travel of the electron in the direction of the field is called Townsend's 1st ionization co-efficient. It depends on the gas pressure and E/P

14. What is meant by Townsend discharge and explain its main feature? (CO2-L1-NOV2014)

When the voltage between anode and cathode is increased the current in the anode equals the current in the external circuit. Therefore the current becomes infinitely large under the above mentioned condition but practically it is limited by the resistance of external circuit and practically by the voltage drop in the arc. The condition $Ve^{ac} = 1$ defines the condition for the beginning of spark and is known as Townsend's criterion for spark formation or breakdown.

15. What are the different theories related with liquid dielectric breakdown? (CO2-L1-NOV2014)

The first theory is extension of gaseous breakdown based on the avalanche ionization of atoms caused electron collision in the applied field. The second theory is based on the fact the presence of foreign particles in liquid insulation is polarizable and is of higher permittivity than the liquid.

16. Distinguish between insulators and dielectrics and give examples for each. (CO2-L2-NOV2014)

A dielectric is a non-conducting substance ie, an insulator. Although the dielectric and insulator are generally considered synonymous the term dielectric is more often used to describe the material where the dielectric polarization is important like the insulating material between the metallic plates of a capacitor while insulator is more often used when the material is being used to prevent a current flow across it.

Examples of insulators: Glass and porcelain

Examples of dielectric: Paper and Mica

17. What are Meta stable atoms? How they are ionizing the gaseous dielectric medium?

A Meta stable atom or a molecule is an excited particle whose life time is very large (10^{-3} sec) compared to the life time of an ordinary particle. Meta stables have a relatively high potential energy and are therefore able to ionize neutral particles.

18. What is composite dielectric? (CO2-L1-NOV2014)

It is difficult to imagine complete insulation system in electrical equipment which does not consist of more than one type of insulation. If insulation as a whole is considered, it will be found that more than one insulating material is used. These different materials can be in parallel with each other such as air or SF₆ in parallel with solid insulation or in series with one another. Such insulation systems are called composite dielectrics.

19. Define formative time lag. (CO2-L1-NOV2014)

After the appearance of the electron a time t_f is required for the ionization processes to develop fully to cause the breakdown of the gap and this time is called formative time lag.

20. Define penning effect. (CO2-L1-NOV2014)

A small percentage of Argon in Neon reduces substantially the dielectric strength of pure Neon. In fact, the dielectric strength is smaller than the dielectric strengths of either pure Neon or Argon. The lowering of dielectric strength is due to the fact that the lowest excited stage of neon is metastable and its excitation potential (16 V) is about 0.9 V greater than the ionization potential of Argon. The metastable atoms have a long life in neon gas, and on hitting Argon atoms there is a very high probability of ionizing them. This phenomenon is known as Penning Effect.

PART B

1. Deduce an expression for townsend's criteria for breakdown of gaseous medium. (CO2-L1-NOV2014)

GASES AS INSULATING MEDIA

- ✓ The simplest and the most commonly found dielectrics are gases. Most of the electrical apparatus use air as the insulating medium, and in a few cases other gases such as nitrogen (N_2), carbon dioxide (CO_2), freon (CCL_2F_2) and sulphur hexafluoride (SF_6) are also used. When the applied voltage is low, small currents flow between the electrodes and the insulation retains its electrical properties.
- ✓ On the other hand, if the applied voltages are large, the current flowing through the insulation increases very sharply, and an electrical breakdown occurs. A strongly conducting spark formed during breakdown practically produces a short circuit between the electrodes.
- ✓ The maximum voltage applied to the insulation at the moment of breakdown is called the breakdown voltage. In order to understand the breakdown phenomenon in gases, a study of the electrical properties of gases and the processes by which high currents are produced in gases is essential.
- ✓ The electrical discharges in gases are of two types, i.e.
(i). non-sustaining discharges, and (ii) self-sustaining types.
- ✓ The breakdown in a gas, called spark breakdown is the transition of a non-sustaining discharge into a self-sustaining discharge.
- ✓ The build-up of high currents in a breakdown is due to the process known as ionization in which electrons and ions are created from neutral atoms or molecules, and their migration to the anode and cathode respectively leads to high currents.
- ✓ At present two types of theories (i) Townsend theory, and (ii) Streamer theory
- ✓ The various physical conditions of gases, namely, pressure, temperature, electrode field configuration, nature of electrode surfaces, and the availability of initial conducting particles are known to govern the ionization processes

TOWNSENDS FIRST IONIZATION PROCESSES

- ✓ A gas in its normal state is almost a perfect insulator. However, when a high voltage is applied between the two electrodes immersed in a gaseous medium, the gas becomes a conductor and an electrical breakdown occurs. A gas in its normal state is almost a

perfect insulator. However, when a high voltage is applied between the two electrodes immersed in a gaseous medium, the gas becomes a conductor and an electrical breakdown occurs.

- ✓ The processes that are primarily responsible for the breakdown of a gas are ionization by collision, photo-ionization, and the secondary ionization processes. In insulating gases (also called electron-attaching gases) the process of attachment also plays an important role.

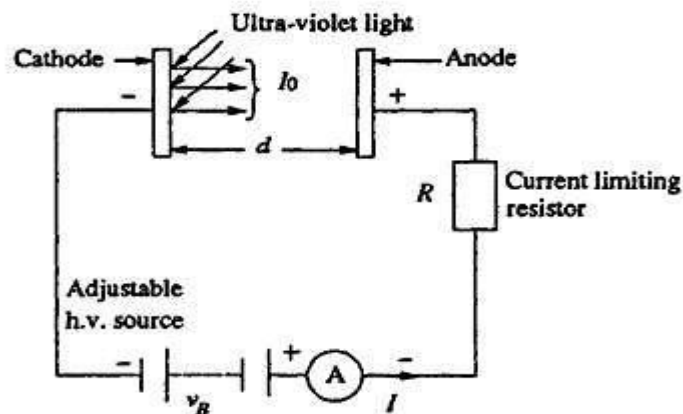

Ionization by Collision

- ✓ The process of liberating an electron from a gas molecule with the simultaneous production of a positive ion is called ionization.
- ✓ In the process of ionization by collision, a free electron collides with a neutral gas molecule and gives rise to a new electron and a positive ion. In a low pressure gas column in which an electric field E is applied across two plane parallel electrodes, then, any electron starting at the cathode will be accelerated more and more between collisions with other gas molecules during its travel towards the anode.
- ✓ If the energy (E) gained during this travel between collisions exceeds the ionisation potential, V_i which is the energy required to dislodge an electron from its atomic shell, then ionisation takes place. This process can be represented as

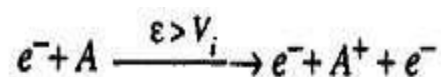

- ✓ Where, A is the atom, A^+ is the positive ion and e^- is the electron. A few of the electrons produced at the cathode by some external means, say by ultra-violet light falling on the cathode,
- ✓ ionise neutral gas particles producing positive ions and additional electrons.
- ✓ The additional electrons, then, themselves make 'ionising collisions' and thus the process repeats itself. This represents an increase in the electron current, since the number of electrons reaching the anode per unit time is greater than those liberated at the cathode.
- ✓ In addition, the positive ions also reach the cathode and on bombardment on the cathode give rise to secondary electrons.

TOWNSEND'S FIRST IONIZATION COEFFICIENT

- ✓ Consider a parallel plate capacitor having gas as an insulating medium and separated by a distance d as shown in Fig.1.1. When no electric field is set up between the plates, a state of equilibrium exists between the state of electron and positive ion generation due to the decay processes. This state of equilibrium will be disturbed moment a high electric field is applied.
- ✓ The variation of current as a function of voltage was studied by Townsend. He found that the current at first increased proportionally as the voltage is increased and then remains constant, at I_0 which corresponds to the saturation current. At still higher voltages, the current increases exponentially. The variation of current as a function of voltage is shown in Fig..
- ✓ The exponential increase in current is due to ionization of gas by electron collision. As the voltage increases V/d increases and hence the electrons are accelerated more and more and between collisions these acquire higher kinetic energy and, therefore, knock out more and more electrons.
- ✓ To explain the exponential rise in current, Townsend introduced a coefficient α known as Townsend's first ionization coefficient and is defined as the number of electrons produced by an electron per unit length of path in the direction of field.

- ✓ Let n_0 be the number of electrons leaving the cathode and when these have moved through a distance x from the cathode, these become n . Now then these n electrons move through a distance dx produce additional d_n electrons due to collision.

$$dn = \alpha n dx$$

or
$$\frac{dn}{n} = \alpha dx$$

or
$$\ln n = \alpha x + A$$

Now at $x = 0$, $n = n_0$. Therefore,

$$\ln n_0 = A$$

or
$$\ln n = \alpha x + \ln n_0$$

or
$$\ln \frac{n}{n_0} = \alpha x$$

At $x = d$, $n = n_0 e^{\alpha d}$. Therefore, in terms of current

$$I = I_0 e^{\alpha d}$$

The term $e^{\alpha d}$ is called the electron avalanche and it represents the number of electrons produced by one electron in travelling from cathode to anode.

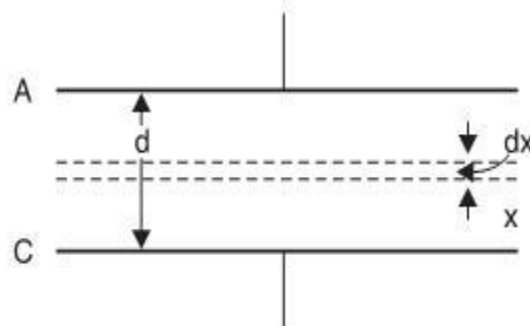

TOWNSEND SECOND IONISATION COEFFICIENT

From the equation

$$I = I_0 e^{\alpha x}$$

We have, taking log on both the sides.

$$\ln I = \ln I_0 + \alpha x$$

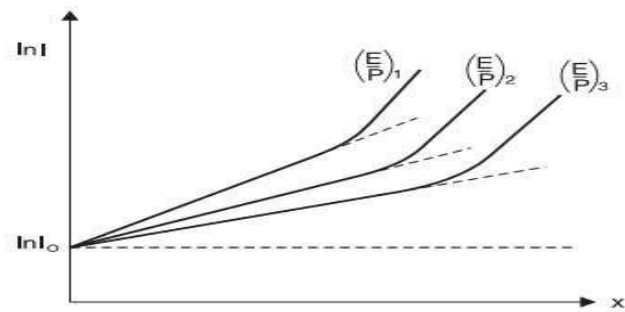

- ✓ This is a straight line equation with slope α and intercept $\ln I_0$ as shown in Fig. if for a given pressure p , E is kept constant. Townsend in his earlier investigations had observed that the current in parallel plate gap increased more rapidly with increase in voltage as compared to the one given by the above equation.
- ✓ Townsend suggested that a second mechanism must be affecting the current. He postulated that the additional current must be due to the presence of positive ions and the photons. The positive ions will liberate electrons by collision with gas molecules and by bombardment against the cathode. Similarly, the photons will also release electrons after collision with gas molecules and from the cathode after photon impact. The phenomenon of self-sustained discharge where the electrons are released from the cathode by positive ion bombardment.
- ✓ Let n_0 be the number of electrons released from the cathode by ultraviolet radiation, n_+ the number of electrons released from the cathode due to positive ion bombardment and n the number of electrons reaching the anode.
- ✓ Let ν , known as Townsend second ionization co-efficient be defined as the number of electrons released from cathode per incident positive ion, Then

$$n = (n_0 + n_+)e^{\alpha d}$$

Now total number of electrons released from the cathode is $(n_0 + n_+)$ and those reaching the anode are n , therefore, the number of electrons released from the gas = $n - (n_0 + n_+)$, and corresponding to each electron released from the gas there will be one positive ion and assuming each positive ion releases ν effective electrons from the cathode then

$$n_+ = v[n - (n_0 + n_+)]$$

or

$$n_+ = vn - vn_0 - vn_+$$

or

$$(1 + v)n_+ = v(n - n_0)$$

or

$$n_+ = \frac{v(n - n_0)}{1 + v}$$

Substituting n_+ in the previous expression for n , we have

$$n = \left[n_0 + \frac{v(n - n_0)}{1 + v} \right] e^{\alpha d} = \frac{(1 + v)n_0 + vn - vn_0}{1 + v} e^{\alpha d}$$

$$= \frac{n_0 + vn}{1 + v} e^{\alpha d}$$

or

$$(n + vn) = n_0 e^{\alpha d} + vne^{\alpha d}$$

or

$$n + vn - vne^{\alpha d} = n_0 e^{\alpha d}$$

or

$$n[1 + v - ve^{\alpha d}] = n_0 e^{\alpha d}$$

or

$$n = \frac{n_0 e^{\alpha d}}{1 + v - ve^{\alpha d}} = \frac{n_0 e^{\alpha d}}{1 - v(e^{\alpha d} - 1)}$$

In terms of current

$$I = \frac{I_0 e^{\alpha d}}{1 - v(e^{\alpha d} - 1)}$$

Earlier Townsend derived an expression for current as

$$I = I_0 \frac{(\alpha - \beta) e^{(\alpha - \beta)d}}{\alpha - \beta e^{(\alpha - \beta)d}}$$

where β represents the number of ion pairs produced by positive ion travelling 1 cm path in the direction of field.

Townsend's original suggestion that the positive ion after collision with gas molecule releases electron does not hold good as ions rapidly lose energy in elastic collision and ordinarily are unable to gain sufficient energy from the electric field to cause ionization on collision with gas molecules or atoms.

In practice positive ions, photons and metastable, all the three may participate in the process of ionization. It depends upon the experimental conditions. There may be more than one mechanism producing secondary ionization in the discharge gap and, therefore, it is customary to express the net secondary ionization effect by a single coefficient v and represent the current by

the above equation keeping in mind that v may represent one or more of the several possible mechanism.

$$V = V_1 + V_2 + V_3 + \dots$$

It is to be noted that the value of v depends upon the work function of the material. If the work function of the cathode surface is low, under the same experimental conditions will produce more emission. Also, the value of v is relatively small at low value of E/p and will increase with increase in E/p .

This is because at higher values of E/p , there will be more number of positive ions and photons of sufficiently large energy to cause ionization upon impact on the cathode surface. It is to be noted that the influence of v on breakdown mechanism is restricted to Townsend breakdown mechanism i.e., to low-pressure breakdown only.

2.Explain streamer breakdown. (CO2-L1-MAY2013)

STREAMER OR KANAL MECHANISM OF SPARK

We know that the charges in between the electrodes separated by a distance d increase by a factor $e^{\alpha d}$ when field between electrodes is uniform. This is valid only if we assume that the field $E_0 = V/d$ is not affected by the space charges of electrons and positive ions.

Reather has observed that if the charge concentration is higher than 10^6 but lower than 10^8 the growth of an avalanche is weakened i.e., $dn/dx < e^{\alpha d}$. Whenever the concentration exceeds 10^8 , the avalanche current is followed by steep rise in current and breakdown of the gap takes place.

The weakening of the avalanche at lower concentration and rapid growth of avalanche at higher concentration have been attributed to the modification of the Fig. Field redistribution due to space charge electric field E_0 due to the space charge field. Fig.shows the electric field around an avalanche as it progresses along the gap and the resultant field i.e., the superposition of the space charge field and the original field E_0 .

Since the electrons have higher mobility, the space charge at the head of the avalanche is considered to be negative and is assumed to be concentrated within a spherical volume. It can be seen from Fig. 1.4 that the field at the head of the avalanche is strengthened.

The field between the two assumed charge centres i.e., the electrons and positive ions is decreased as the field due to the charge centres opposes the main field E_0 and again the field between the positive space charge centre and the cathode is strengthened as the space charge field aids the main field E_0 in this region.

It has been observed that if the charge carrier number exceeds 10^6 , the field distortion becomes noticeable. If the distortion of field is of 1%, it would lead to a doubling of the avalanche but as the field distortion is only near the head of the avalanche, it does not have a significance on the discharge phenomenon.

However, if the charge carrier exceeds 10^8 , the space charge field becomes almost of the same magnitude as the main field E_0 and hence it may lead to initiation of a streamer. The space charge field, therefore, plays a very important role in the mechanism of electric discharge in a non-uniform gap.

Townsend suggested that the electric spark discharge is due to the ionization of gas molecule by the electron impact and release of electrons from cathode due to positive ion bombardment at the cathode. According to this theory, the formative time lag of the spark should be at best equal to the electron transit time t .

At pressures around atmospheric and above $p.d. > 10^3$ Torr-cm, the experimentally determined time lags have been found to be much shorter than t_r . Study of the photographs of the avalanche development has also shown that under certain conditions, the space charge developed in an avalanche is capable of transforming the avalanche into channels of ionization known as streamers that lead to rapid development of breakdown.

It has also been observed through measurement that the transformation from avalanche to streamer generally takes place when the charge within the avalanche head reaches a critical value of where X_c is the length of the avalanche path in field direction when it reaches the critical size. If the gap length $d < X_c$, the initiation of streamer is unlikely.

The short-time lags associated with the discharge development led Raether and independently Meek and Meek and Loeb to the advancement of the theory of streamer of Kanal mechanism for spark formation, in which the secondary mechanism results from photoionization of gas molecules and is independent of the electrodes.

Raether and Meek have proposed that when the avalanche in the gap reaches a certain critical size the combined space charge field and externally applied field E_0 lead to intense ionization and excitation of the gas particles in front of the avalanche head. There is

recombination of electrons and positive ion resulting in generation of photons and these photons in turn generate secondary electrons by the photoionization process.

These electrons under the influence of the electric field develop into secondary avalanches as shown in Fig. Since photons travel with velocity of light, the process leads to a rapid development of conduction channel across the gap.

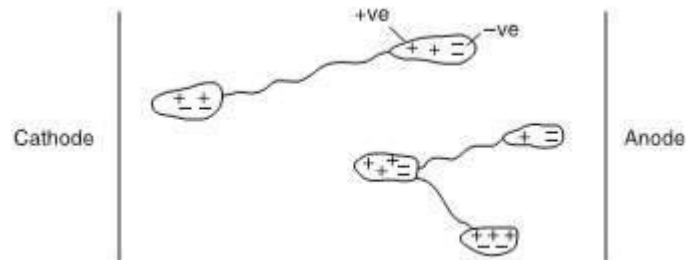

- ✓ Raether after thorough experimental investigation developed an empirical relation for the streamer spark criterion of the form

$$\alpha x_c = 17.7 + \ln x_c + \ln \frac{E_r}{E_0}$$

- ✓ where E_r is the radial field due to space charge and E_0 is the externally applied field. Now for transformation of avalanche into a streamer $E_r \approx E$

$$\alpha x_c = 17.7 + \ln x_c$$

- ✓ For a uniform field gap, breakdown voltage through streamer mechanism is obtained on the assumption that the transition from avalanche to streamer occurs when the avalanche has just crossed the gap. The equation above, therefore, becomes

$$\alpha d = 17.7 + \ln d$$

- ✓ When the critical length $x_c \geq d$ minimum breakdown by streamer mechanism is brought about. The condition $x_c = d$ gives the smallest value of α to produce streamer breakdown. Meek suggested that the transition from avalanche to streamer takes place when the radial field about the positive space charge in an electron avalanche attains a value of the order of the externally applied field. He showed that the value of the radial field can be obtained by using the expression.

$$E_r = 5.3 \times 10^{-7} \frac{\alpha e^{\alpha x}}{(x/P)^{1/2}} \text{ volts/cm.}$$

- ✓ where x is the distance in cm which the avalanche has progressed, p the gas pressure in Torr and Townsend coefficient of ionization by electrons corresponding to the applied field E .

- ✓ The minimum breakdown voltage is assumed to correspond to the condition when the avalanche has crossed the apof length d and the space charge field E_r approaches the externally applied field i.e., at $x = d$, $E_r = E$. Substituting these values in the above equation, we have

$$E = 5.3 \times 10^{-7} \frac{\alpha e^{\alpha d}}{(d/p)^{1/2}}$$

Taking ln on both the sides, we have

$$\ln E = -14.5 + \ln \alpha - \frac{1}{2} \ln \frac{d}{p} + \alpha d$$

$$\ln E - \ln p = -14.5 + \ln \alpha - \ln p - \frac{1}{2} \ln \frac{d}{p} + \alpha d$$

$$\ln \frac{E}{p} = -14.5 + \ln \frac{\alpha}{p} - \frac{1}{2} \ln \frac{d}{p} + \alpha d$$

The experimentally determined values of α/p and the corresponding E/p are used to solve the above equation using trial and error method. Values of α/p corresponding to E/p at a given pressure are chosen until the equation is satisfied.

3.State and explain paschen's law. (CO2-L1-NOV2014)

THE SPARKING POTENTIAL—PASCHEN'S LAW

The Townsend's Criterion

$$v(e^{\alpha d} - 1) = 1$$

enables the evaluation of breakdown voltage of the gap by the use of appropriate values of α/p and v corresponding to the values E/p when the current is too low to damage the cathode and also the space charge distortions are minimum.

A close agreement between the calculated and experimentally determined values is obtained when the gaps are short or long and the pressure is relatively low. An expression for the breakdown voltage for uniform field gaps as a function of gap length and gas pressure can be derived from the threshold equation by expressing the ionization coefficient α/p as a function of field strength E and gas pressure p i.e.,

$$\frac{\alpha}{p} = f\left(\frac{E}{p}\right)$$

Substituting this, we have

$$e^{f(E/p) pd} = \frac{1}{v} + 1$$

Taking ln both the sides, we have

$$f\left(\frac{E}{p}\right) pd = \ln\left[\frac{1}{v} + 1\right] = K \text{ say}$$

For uniform field $E = \frac{V_b}{d}$.

$$\text{Therefore, } f\left(\frac{V_b}{pd}\right) \cdot pd = K$$

$$\text{or } f\left(\frac{V_b}{pd}\right) = \frac{K}{pd}$$

$$\text{or } V_b = F(pd)$$

This shows that the breakdown voltage of a uniform field gap is a unique function of the product of gas pressure and the gap length for a particular gas and electrode material. This relation is known as Paschen's law. This relation does not mean that the breakdown voltage is directly proportional to product pd even though it is found that for some region of the product pd the relation is linear i.e., the breakdown voltage varies linearly with the product pd . The variation over a large range is shown in Fig

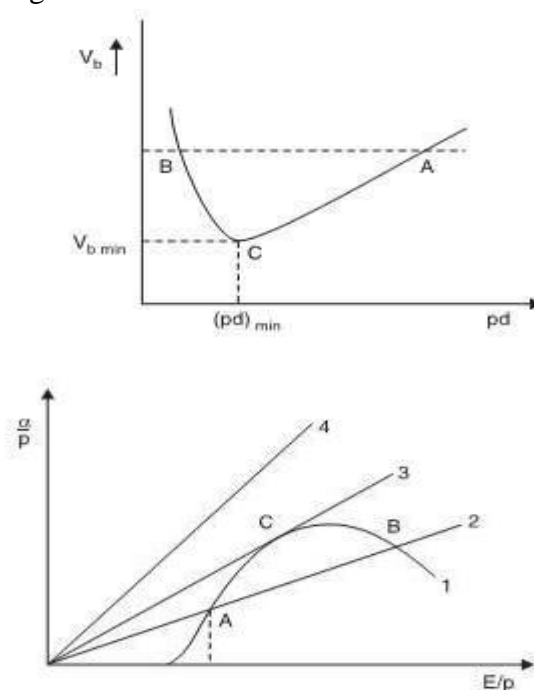

4.Explain the phenomenon of corona discharges and breakdown mechanism in non uniform field. (CO2-L1-NOV2014)**CORONA DISCHARGES**

If the electric field is uniform and if the field is increased gradually, just when measurable ionization begins, the ionization leads to complete breakdown of the gap. However, in non-uniform fields, before the spark or breakdown of the medium takes place, there are many manifestations in the form of visual and audible discharges. These discharges are known as Corona discharges.

In fact Corona is defined as a self-sustained electric discharge in which the field intensified ionization is localized only over a portion of the distance (non-uniform fields) between the electrodes. The phenomenon is of particular importance in high voltage engineering where most of the fields encountered are non-uniform fields unless of course some design features are involved to make the field almost uniform.

Corona is responsible for power loss and interference of power lines with the communication lines as corona frequency lies between 20 Hz and 20 kHz. This also leads to deterioration of insulation by the combined action of the discharge ion bombarding the surface and the action of chemical compounds that are formed by the corona discharge.

When a voltage higher than the critical voltage is applied between two parallel polished wires, the glow is quite even. After operation for a short time, reddish beads or tufts form along the wire, while around the surface of the wire there is a bluish white glow.

If the conductors are examined through a stroboscope, so that one wire is always seen when at a given half of the wave, it is noticed that the reddish tufts or beads are formed when the conductor is negative and a smoother bluish white glow when the conductor is positive.

The a.c. corona viewed through a stroboscope has the same appearance as direct current corona. As corona phenomenon is initiated a hissing noise is heard and ozone gas is formed which can be detected by its characteristic colour.

When the voltage applied corresponds to the critical disruptive voltage, corona phenomenon starts but it is not visible because the charged ions in the air must receive some finite energy to cause further ionization by collisions.

For a radial field, it must reach a gradient (visual corona gradient) g_u at the surface of the conductor to cause a gradient g_0 , finite distance away from the surface of the conductor.

The distance between g_0 and g_v is called the energy distance. From this it is clear that g_v is not constant as g_0 is, and is a function of the size of the conductor. The electric field intensity for two parallel wires is given as

$$E = 30 \left(1 + \frac{0.301}{\sqrt{r} \delta} \right) \delta \text{ kV/cm}$$

$$E = 30 \left(1 + \frac{0.308}{\sqrt{r} \delta} \right) \delta$$

Investigation with point-plane gaps in air have shown that when point is positive, the corona current increases steadily with voltage. At sufficiently high voltage, current amplification increases rapidly with voltage up to a current of about 10^{-7} A, after which the current becomes pulsed with repetition frequency of about 1 kHz composed of small bursts.

This form of corona is known as burst corona. The average current then increases steadily with applied voltage, leading to breakdown. With point-plane gap in air when negative polarity voltage is applied to the point and the voltage exceeds the onset value, the current flows in vary regular pulses known as Trichel pulses.

The onset voltage is independent of the gap length and is numerically equal to the onset of streamers under positive voltage for the same arrangement. The pulse frequency increases with voltage and is a function of the radius of the cathode, the gap length and the pressure.

A decrease in pressure decreases the frequency of the pulses. It should be noted that the breakdown voltage with negative polarity is higher than with positive polarity except at low pressure.

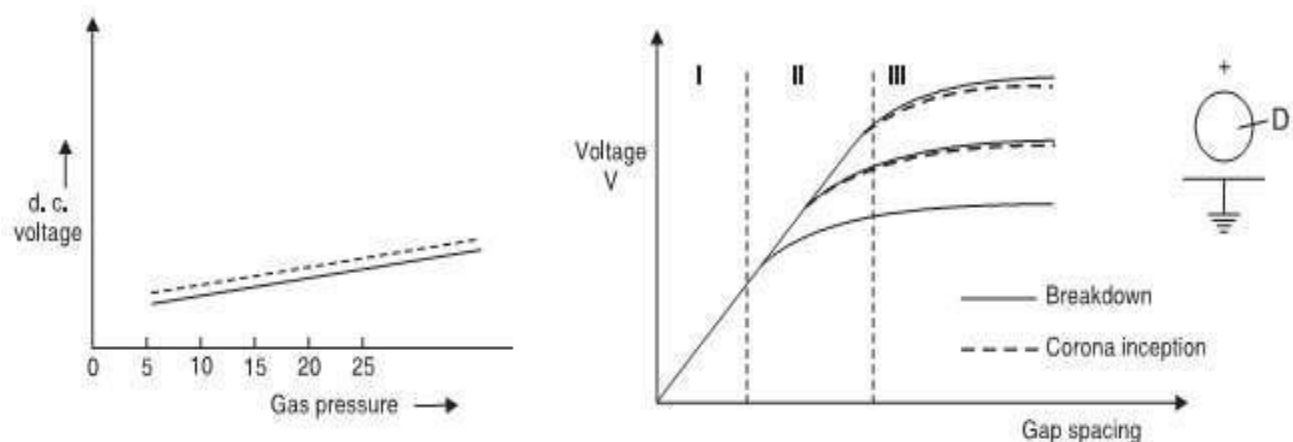

Therefore, under alternating power frequency voltage the breakdown of non-uniform field gap invariably takes place during the positive half cycle of the voltage wave. Fig. gives comparison between the positive and negative point-plane gap breakdown characteristics measured in air as a function of gas pressure

When the spacing is small the breakdown characteristics for the two polarities nearly coincide and no corona stabilized region is observed. As the spacing is increased, the positive characteristics display the distinct high corona breakdown up to a pressure of about 7 bars, followed by a sudden drop in breakdown strengths.

Under the negative polarity, the corona stabilized region extends to much higher pressures. Fig. shows the corona inception and breakdown voltages of the sphere-plane arrangement. From the figure, it is clear that

- (i) For small spacing (Zone-I), the field is uniform and the breakdown voltage depends mainly on the gap spacing.
- (ii) In zone-II, where the spacing is relatively larger, the electric field is non-uniform and the breakdown voltage depends on both the sphere diameter and the spacing.
- (iii) For still larger spacings (Zone-III) the field is non-uniform and the breakdown is preceded by corona and is controlled only by the spacing. The corona inception voltage mainly depends on the sphere diameter.

TIME-LAG

In order to breakdown a gap, certain amount of energy is required. Also it depends upon the availability of an electron between the gap for initiation of the avalanche. Normally the peak value of A.C. and D.C. are smaller as compared to impulse wave as the duration of the former are pretty large as compared to the latter and the energy content is large.

Also with D.C. and A.C. as the duration is large there are usually sufficient initiatory electrons created by cosmic ray and naturally occurring radioactive sources. Suppose V_d is the maximum value of D.C. volt-age applied for a long time to cause breakdown of a given gap. Fig. 1.10. Let the same gap be subjected to a step volt-age of peak value $V_{d1} > V_d$ and of a duration such that the gap breaks down in time t .

If the breakdown were purely a function of voltage magnitude, the breakdown should have taken place the moment the step voltage had just crossed the voltage V_d . The time that elapses between the application of the voltage to a gap sufficient to cause breakdown, and the breakdown, is called the time lag. In the given case shown in Fig. 1.10, t is the time lag.

It consists of two components.

One is the that elapses during the voltage applications until a primary electron appears to initiate the discharge and is known as the statistical time lag t_s and the other is the time required for the breakdown to develop once initiated and is known as the formative time lag t_f .

The statistical time lag depends upon (i) The amount of pre-ionization present in between the gap (ii) Size of the gap (iii) The amount of over voltage ($V_{d1} - V_d$) applied to the gap. The larger the gap the higher is going to be the statistical time lag. Similarly, a smaller over voltage results in higher statistical time lag. However, the formative time lag depends mainly on the mechanism of breakdown.

In cases when the secondary electrons arise entirely from electron emission at the cathode by positive ions, the transit time from anode to cathode will be the dominant factor determining the formative time. The formative time lag increases with increase in gap length and field non-uniformity, decreases with increase in over voltage applied.

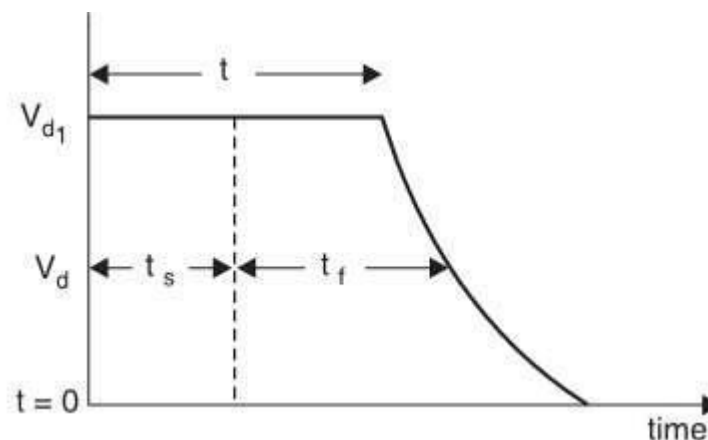

Breakdown in Electronegative Gases

SF₆, has excellent insulating strength because of its affinity for electrons (electronegativity) i.e., whenever a free electron collides with the neutral gas molecule to form negative ion, the electron is absorbed by the neutral gas molecule. The attachment of the electron with the neutral gas molecule may occur in two ways:

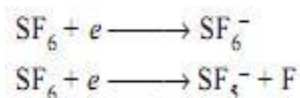

The negative ions formed are relatively heavier as compared to free electrons and, therefore, under a given electric field the ions do not attain sufficient energy to lead cumulative ionization in the gas. Thus, these processes represent an effective way of removing electrons from the space which otherwise would have contributed to form electron avalanche. This property, therefore, gives rise to very high dielectric strength for SF₆.

The gas not only possesses a good dielectric strength but it has the unique property of fast recombination after the source energizing the spark is removed. The dielectric strength of SF₆ at normal pressure and temperature is 2–3 times that of air and at 2 atm its strength is comparable with the transformer oil.

Although SF₆ is a vapour, it can be liquefied at moderate pressure and stored in steel cylinders. Even though SF₆ has better insulating and arc-quenching properties than air at an equal pressure, it has the important disadvantage that it cannot be used much above 14 kg/cm² unless the gas is heated to avoid liquefaction.

Application of Gases in Power System

The gases find wide application in power system to provide insulation to various equipment and substations. The gases are also used in circuit breakers for arc interruption besides providing insulation between breaker contacts and from contact to the enclosure used for contacts. The various gases used are (i) air (ii) oxygen (iii) hydrogen (iv) nitrogen (v) CO₂ and (vi) electronegative gases like sulphur hexafluoride, arcton etc.

The various properties required for providing insulation and arc interruptions are:

- (i) High dielectric strength.
- (ii) Thermal and chemical stability
- (iii) Non-inflammability.
- (iv) High thermal conductivity. This assists cooling of current carrying conductors immersed in the gas and also assists the arc-extinction process.
- (v) Arc extinguishing ability. It should have a low dissociation temperature, a short thermal time constant (ratio of energy contained in an arc column at any instant to the rate of energy dissipation at the same instant) and should not produce conducting products such as carbon during arcing.
- (vi) Commercial availability at moderate cost. Of the simple gases air is the cheapest and most widely used for circuit breaking. Hydrogen has better arc extinguishing property but it has lower dielectric strength as compared with air. Also if hydrogen is contaminated with air, it forms an explosive mixture.
- (vii) Nitrogen has similar properties as air, CO₂ has almost the same dielectric strength as air but is a better arc extinguishing medium at moderate currents. Oxygen is a good extinguishing medium but is chemically active. SF₆ has

outstanding arc-quenching properties and good dielectric strength. Of all these gases, SF₆ and air are used in commercial gas blast circuit breakers.

Air at atmospheric pressure is 'free' but dry air costs a lot when stored at say 75 atmosphere. The compressed air supply system is a vital part of an air blast C.B. Moisture from the air is removed by refrigeration, by drying agents or by storing at several times the working pressure and then expanding it to the working pressure for use in the C.B. The relative cost of storing the air reduces with increase in pressure. If the air to be used by the breaker is at 35 kg/cm² it is common to store it at 210 kg/cm².

Air has an advantage over the electronegative gases in that air can be compressed to extremely high pressures at room temperature and then its dielectric strength even exceeds that of these gases. The SF₆ gas is toxic and its release in the form of leakage causes environmental problems. Therefore, the electrical industry has been looking for an alternative gas or a mixture of SF₆ with some other gas as an insulating and arc interrupting medium.

It has been observed that a suitable mixture of SF₆ with N₂ is a good replacement for SF₆. This mixture is not only finding acceptability for providing insulation e.g., gas insulated substation and other equipment, it is able to quench high current magnitude arcs. The mixture is not only cost effective, it is less sensitive to find non-uniformities present within the equipment.

Electric power industry is trying to find optimum SF₆ to N₂ mixture ratio for various components of the system viz., GIS, C.B., capacitors, CT, PT and cables. A ratio 70% of SF₆ and 30% of N₂ is found to be optimum for circuit breaking. With this ratio, the C.B. has higher recovery rate than pure SF₆ at the same partial pressure. The future of using SF₆ with N₂ or He for providing insulation and arc interruption is quite bright.

5. Explain clearly various process which explain electric breakdown in vacuum (CO2-L1-NOV2014)

Vacuum Breakdown

In the Townsend type of discharge in a gas described earlier, electrons get multiplied due to various ionization processes and an electron avalanche is formed. In a high vacuum, even if the electrodes are separated by, say, a few centimeters, an electron crosses the gap without encountering any collisions. Therefore, the current growth prior to breakdown cannot be due to the formation of electron avalanches.

However, if a gas is liberated in the vacuum gap, then, breakdown can occur in the manner described by the Townsend process. Thus, the various breakdown mechanisms in high

vacuum aim at establishing the way in which the liberation of gas can be brought about in a vacuum gap. During the last 70 years or so, many different mechanisms for breakdown in vacuum have been proposed. These can be broadly divided into three categories

- (a) Particle exchange mechanism
- (b) Field emission mechanism
- (c) lump theory

(a) Particle Exchange Mechanism

In this mechanism it is assumed that a charged particle would be emitted from one electrode under the action of the high electric field, and when it impinges on the other electrode, it liberates oppositely charged particles. These particles are accelerated by the applied voltage back to the first electrode where they release more of the original type of particles. When this process becomes cumulative, a chain reaction occurs which leads to the breakdown of the gap. The particle-exchange mechanism involves electrons, positive ions, photons and the absorbed gases at the electrode surfaces.

Qualitatively, an electron present in the vacuum gap is accelerated towards the anode, and on impact releases A positive ions and C photons. These positive ions are accelerated towards the cathode, and on impact each positive ion liberates B electrons and each photon liberates D electrons. This is shown schematically in Fig. 2.24. The breakdown will occur if the coefficient of production of secondary electrons exceeds unity. Mathematically, the condition for breakdown can be written as

$$(AB + CD) > 1$$

Later, Trump and Van de Graaff measured these coefficients and showed that they were too small for this process to take place. Accordingly, this theory was modified to allow for the presence of negative ions and the criterion for breakdown then becomes Where A and B are the same as before and E and F represent the coefficients for negative and positive ion liberation by positive and negative ions.

$$(AB + EF) > 1$$

It was experimentally found that the values of the product EF were close enough to unity for copper, aluminum and stainless steel electrodes to make this mechanism applicable at voltages above 250 kV.

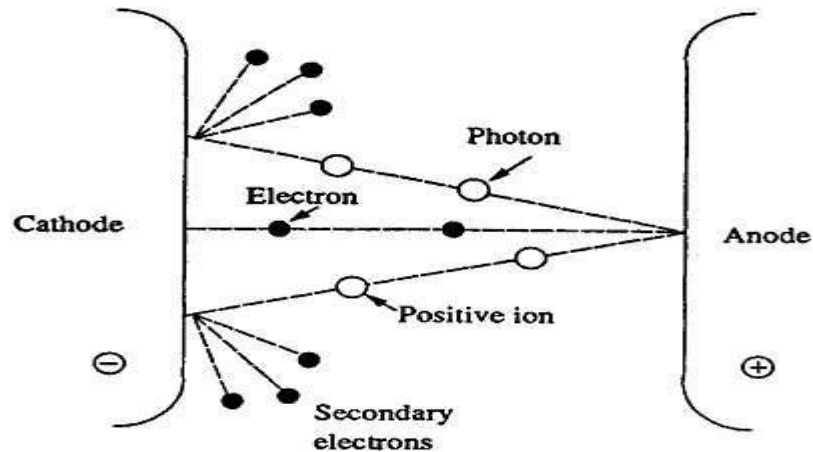

Field Emission Theory

(i) Anode Heating Mechanism

This theory postulates that electrons produced at small micro-projections on the cathode due to field emission bombard the anode causing a local rise in temperature and release gases and vapours into the vacuum gap. These electrons ionise the atoms of the gas and produce positive ions.

These positive ions arrive at the cathode, increase the primary electron emission due to space charge formation and produce secondary electrons by bombarding the surface. The process continues until a sufficient number of electrons are produced to give rise to breakdown, as in the case of a low pressure Townsend type gas discharge. This is shown schematically in Fig.

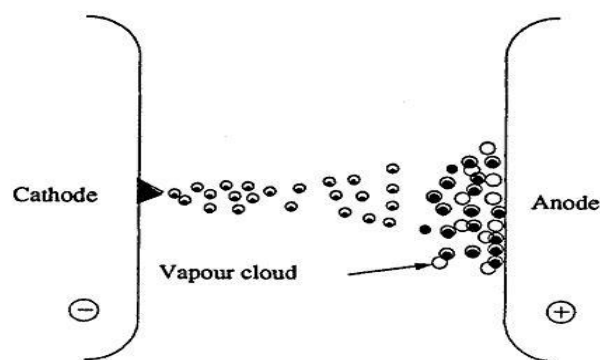

(ii) Cathode Heating Mechanism

This mechanism postulates that near the breakdown voltages of the gap, sharp points on the cathode surface are responsible for the existence of the pre-breakdown current, which is generated according to the field emission process described below. These current causes resistive

heating at the tip of a point and when a critical current density is reached, the tip melts and explodes, thus initiating vacuum discharge.

This mechanism is called field emission as shown schematically in Fig. 2.26. Thus, the initiation of breakdown depends on the conditions and the properties of the cathode surface. Experimental evidence shows that breakdown takes place by this process when the effective cathode electric field is of the order of 10^6 to 10^7 V/cm.

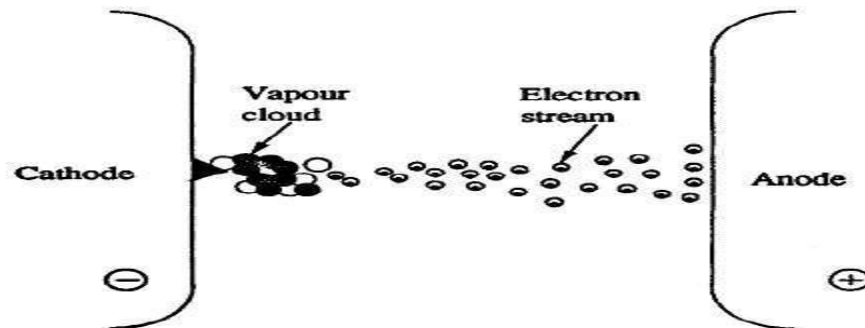

Clump Mechanism

Basically this theory has been developed on the following assumptions. A loosely bound particle (clump) exists on one of the electrode surfaces. On the application of a high voltage, this particle gets charged, subsequently gets detached from the mother electrode, and is accelerated across the gap. (///)

The breakdown occurs due to a discharge in the vapour or gas released by the impact of the particle at the target electrode. Cranberg was the first to propose this theory. He initially assumed that breakdown will occur when the energy per unit area, W_9 delivered to the target electrode by a clump exceeds a value C , a constant, characteristic of a given pair of electrodes. The quantity W is the product of gap voltage (V) and the charge density on the clump. The latter is proportional to the electric field E at the electrode of origin. The criterion for breakdown, therefore, is

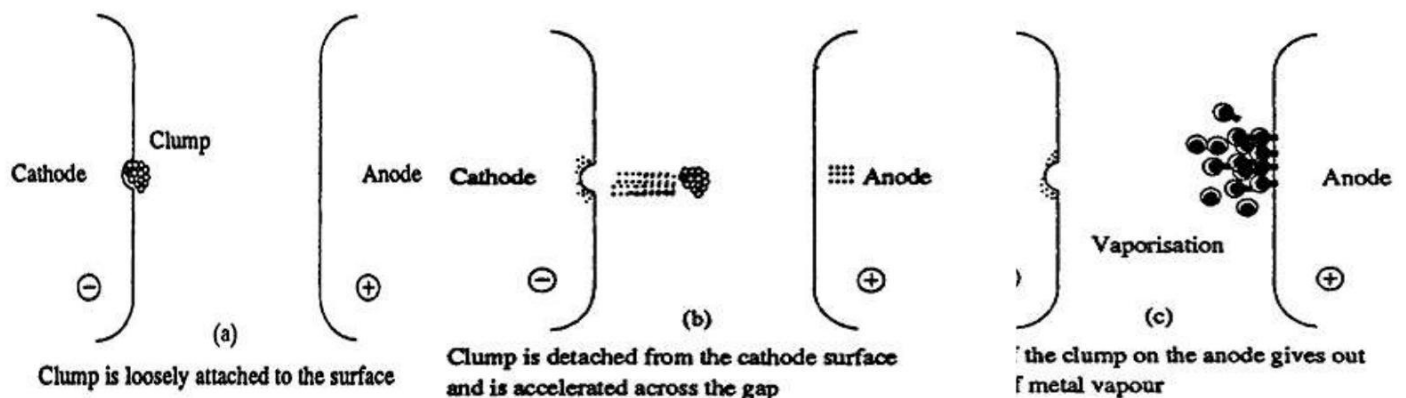

In case of parallel plane electrodes the field $E = V/d$, where d is the distance between the electrodes. So the generalized criterion for breakdown becomes

$$V = (C d)^{1/2}$$

Where C is another constant involving C and the electrode surface conditions. Cranberg presented a summary of the experimental results which satisfied this breakdown criterion with reasonable accuracy. However the equation was later modified as $V = C d_0^{1/2}$, where a varies between 0.2 and 1.2 depending on the gap length and the electrode material, with a maximum at 0.6. The dependence of V on the electrode material comes from the observations of markings on the electrode surfaces. Craters were observed on the anode and melted regions on the cathode or vice-versa after a single breakdown.

6.Explain the various characteristic in pure liquid dielectric. (CO2-L1-NOV2014)

CONDUCTION AND BREAKDOWN IN PURE LIQUIDS

When low electric fields less than 1 kV/cm are applied, conductivities of 10^{-18} to 10^{-20} mho/cm are obtained. These are probably due to the impurities remaining after purification. However, when the fields are high (> 100 kV/cm) the currents not only increase rapidly, but also undergo violent fluctuations which will die down after some time.

A typical mean value of the conduction current in hexane is shown in Fig. 3.2. Reservoir To vacuum pump Distillation column To vacuum pump Test cell with electrodes Vacuum valve To vacuum pump The exact mechanism of current growth is not known; however, it appears that the electrons are generated from the cathode by field emission of electrons.

The electrons so liberated get multiplied by a process similar to Townsend's primary and secondary ionization in gases. As the breakdown field is approached, the current increases rapidly due to a process similar to the primary ionization process and also the positive ions reaching the cathode generate secondary electrons, leading to breakdown.

The breakdown voltage depends on the field, gap separation, cathode work-function, and the temperature of the cathode. In addition, the liquid viscosity, the liquid temperature, the density, and the molecular structure of the liquid also influence the breakdown strength of the liquid.

Typical maximum Vacuum gauge Cooling tower Filter This is the condition nearer to break-down. However, if this figure is redrawn starting from very small currents, a current-

electric field characteristic as shown in Fig. 3.3, can be obtained. This curve will have three distinct regions as shown. At very low fields the current is due to the dissociation of ions.

With intermediate fields the current reaches a saturation value, and at high fields the current generated because of the field-aided electron emission from the cathode gets multiplied in the liquid medium. It has been observed that the increase in breakdown strength is more, if the dissolved gases are electronegative in character (like oxygen).

Similarly, the increase in the liquid hydrostatic pressure increases the breakdown strength. To sum up, this type of breakdown process in pure liquids, called the electronic breakdown, involves emission of electrons at fields greater than 100 kV/cm.

This emission occurs either at the electrode surface irregularities or at the interfaces of impurities and the liquid. These electrons get further multiplied by Townsend's type of primary and secondary ionisation

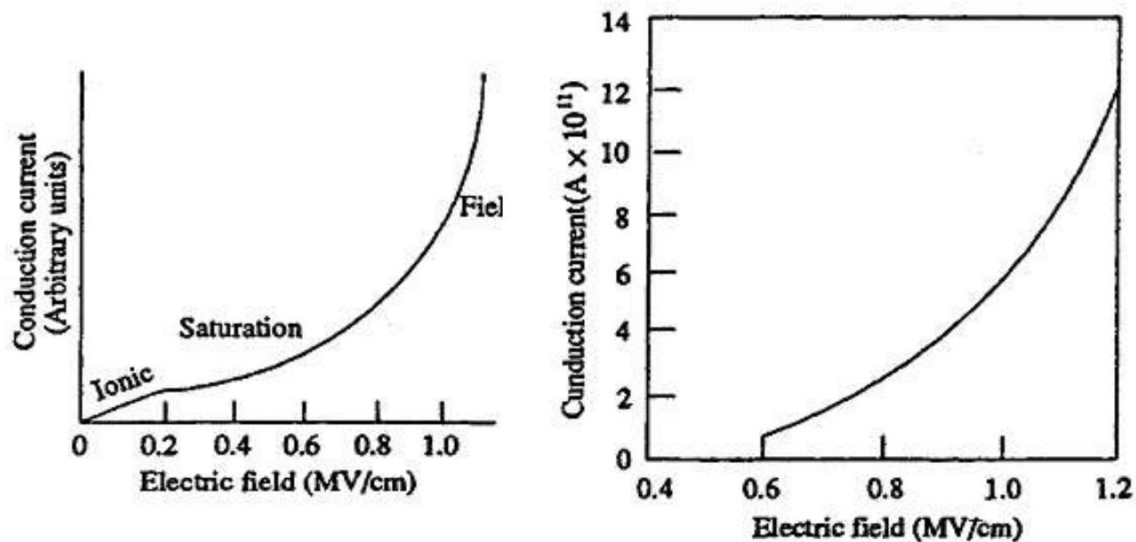

6. Explain the various theory involved in commercial liquid dielectric. (CO2-L1-NOV2014)

CONDUCTION AND BREAKDOWN IN COMMERCIAL LIQUIDS

Commercial insulating liquids are not chemically pure and have impurities like gas bubbles, suspended particles, etc. These impurities reduce the breakdown strength of these liquids considerably.

The breakdown mechanisms are also considerably influenced by the presence of these impurities. In addition, when breakdown occurs in these liquids, additional gases and gas bubbles are evolved and solid decomposition products are formed.

The electrode surfaces become rough, and at times explosive sounds are heard due to the generation of impulsive pressure through the liquid.

The breakdown mechanism in commercial liquids is dependent, as seen above, on several factors, such as, the nature and condition of the electrodes, the physical properties of the liquid, and the impurities and gases present in the liquid. Several theories have been proposed to explain the breakdown in liquids, and they are classified as follows:

- (a) Suspended Particle Mechanism
- (b) Cavitation and Bubble Mechanism
- (c) Stressed Oil Volume Mechanism

Suspended Particle Theory

In commercial liquids, the presence of solid impurities cannot be avoided. These impurities will be present as fibres or as dispersed solid particles. The permittivity of these particles (ϵ^a) will be different from the permittivity of the liquid. If we consider these impurities to be spherical particles of radius r , and if the applied field is E_9 then the particles experience a force F , where

$$F = \frac{1}{2r^3} \frac{(\epsilon_2 - \epsilon_1)}{2\epsilon_1 + \epsilon_2} \text{grad } E^2$$

this force is directed towards areas of maximum stress, if $\epsilon_2 > \epsilon_1$ for example, in the case of the presence of solid particles like paper in the liquid. On the other hand, if only gas bubbles are present in the liquid, i.e. $\epsilon_2 < \epsilon_1$, the force will be in the direction of areas of lower stress. If the voltage is continuously applied (D.C.) or the duration of the voltage is long (a.c.), then this force drives the particles towards the areas of maximum stress.

If the numbers of particles present are large, they become aligned due to these forces, and thus form a stable chain bridging the electrode gap causing a breakdown between the electrodes. If there is only a single conducting particle between the electrodes, it will give rise to local field enhancement depending on its shape.

If this field exceeds the breakdown strength of the liquid, local breakdown will occur near the particle, and this will result in the formation of gas bubbles which may lead to the breakdown of the liquid.

The values of the breakdown strength of liquids containing solid impurities were found to be much less than the values for pure liquids. The impurity particles reduce the breakdown strength, and it was also observed that the larger the size of the particles the lower were the breakdown strengths.

Cavitation and the Bubble Theory

It was experimentally observed that in many liquids, the breakdown strength depends strongly on the applied hydrostatic pressure, suggesting that a change of phase of the medium is involved in the breakdown process, which in other words means that a kind of vapour bubble formed is responsible for breakdown. The following processes have been suggested to be responsible for the formation of the vapour bubbles:

- (a) Gas pockets at the surfaces of the electrodes;
- (b) Electrostatic repulsive forces between space charges which may be sufficient to overcome the surface tension;
- (c) Gaseous products due to the dissociation of liquid molecules by electron collisions;
- (d) Vaporization of the liquid by corona type discharge from sharp points and irregularities on the electrode surfaces.

Once a bubble is formed it will elongate in the direction of the electric field under the influence of electrostatic forces. The volume of the bubble remains constant during elongation.

Breakdown occurs when the voltage drop along the length of the bubble becomes equal to the minimum value on the Paschen's curve for the gas in the bubble. The breakdown field is given as

$$E_0 = \frac{1}{(\epsilon_1 - \epsilon_2)} \left[\frac{2\pi\sigma(2\epsilon_1 + \epsilon_2)}{r} \left\{ \frac{\pi}{4} \sqrt{\left(\frac{V_b}{2rE_0} \right) - 1} \right\} \right]^{\frac{1}{2}}$$

where σ = surface tension,

R = initial radius of the bubble,

ϵ_1 = permittivity of the liquid dielectric,

This theory does not take into account the production of the initial bubble and hence the results given by this theory do not agree well with the experimental results. This is shown in Fig. 3.6. Later this theory was modified, and it was suggested that only incompressible bubbles like water globules can elongate at constant volume, according to the simple gas law $pV = RT$. Under the influence of the applied electric field the shape of the globule is assumed to be approximately a prolate spheroid. The incompressible bubbles reach the condition of instability when B , the ratio of the longer to the shorter diameter of the spheroid, is about 1.85, and the critical field producing the instability will be:

$$E_c = 600 \sqrt{\frac{\pi \sigma}{\epsilon_1 R}} \left[\frac{\epsilon_1}{\epsilon_1 - \epsilon_2} - G \right] H$$

Thermal Mechanism of Breakdown

Another mechanism proposed to explain breakdown under pulse conditions is thermal breakdown. This mechanism is based on the experimental observations of extremely large currents just before breakdown. These high current pulses are believed to originate from the tips of the microscopic projections on the cathode surface with densities of the order of 1 A/cm³. These high density current pulses give rise to localized heating of the oil which may lead to the formation of vapor bubbles.

The vapor bubbles are formed when the energy exceeds 10 W/cm. When a bubble is formed, breakdown follows, either because of its elongation to a critical size or when it completely bridges the gap between the electrodes.

In either case, it will result in the formation of a spark. According to this mechanism, the breakdown strength depends on the pressure and the molecular structure of the liquid. For example, in alkanes the breakdown strength was observed to depend on the chain length of the molecule.

This theory is only applicable at very small lengths (< 100 μm) and does not explain the reduction in breakdown strength with increased gap lengths

Stressed Oil Volume Theory

In commercial liquids where minute traces of impurities are present, the breakdown strength is determined by the "largest possible impurity" or "weak link". On a statistical basis it was proposed that the electrical breakdown strength of the oil is defined by the weakest region in the oil, namely, the region which is stressed to the maximum and by the volume of oil included in that region.

In non-uniform fields, the stressed oil volume is taken as the volume which is contained between the maximum stress (max) contour and 0.9 max contours. According to this theory the breakdown strength is inversely proportional to the stressed oil volume.

The breakdown voltage is highly influenced by the gas content in the oil, the viscosity of the oil, and the presence of other impurities. These being uniformly distributed, increase in the stressed oil volume consequently results in a reduction in the breakdown voltage. The variation of the breakdown voltage stress with the stressed oil volume is shown in Fig.

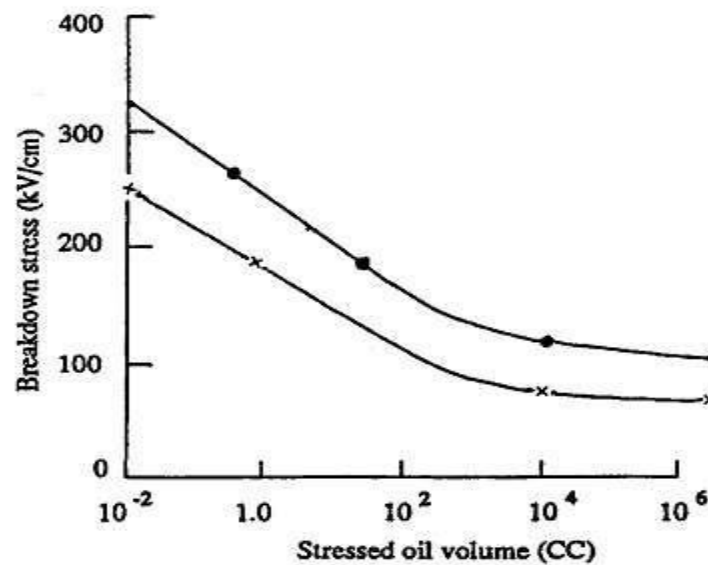

7.Explain the various breakdown mechanism in composite dielectric.(CO2-L1-NOV2014)

Solid dielectric materials are used in all kinds of electrical circuits and devices to insulate one current carrying part from another when they operate at different voltages. A good dielectric should have low dielectric loss, high mechanical strength, should be free from gaseous inclusions, and moisture, and be resistant to thermal and chemical deterioration. Solid dielectrics have higher breakdown strength compared to liquids and gases. The mechanism of breakdown is a complex phenomenon in the case of solids, and varies depending on the time of application of voltage as shown in Fig. 4.1. The various breakdown mechanisms can be classified as follows:

- (a) intrinsic or ionic breakdown,
- (b) electromechanical breakdown,
- (c) failure due to treeing and tracking,
- (d) thermal breakdown,
- (e) electrochemical breakdown, and
- (J) Breakdown due to internal discharges.

INTRINSICBREAKDOWN

When voltages are applied only for short durations of the order of 10^{-8} s the dielectric strength of a solid dielectric increases very rapidly to an upper limit called the intrinsic electric strength. Experimentally, this highest dielectric strength can be obtained only under the best experimental conditions when all extraneous influences have been isolated and the value depends only on the structure of the material and the temperature.

The maximum electrical strength recorded is 15 MV/cm for poly vinyl-alcoholat - 1960C. The maximum strength usually obtainable ranges from 5 MV/cm to 10MV/cm. intrinsic breakdown depend upon the presence of free electrons which are capable of migration through the lattice of the dielectric.

Usually, a small number of conduction elections are present in solid dielectrics, along with some structural imperfections and small amounts of impurities. The impurity atoms, or molecules or both act as traps for the conduction electrons up to certain ranges of electric fields and temperatures.

When these ranges are exceeded, additional electrons in addition to trapped electrons are released, and these electrons participate in the conduction process. Based on this principle, two types of intrinsic breakdown mechanisms have been proposed.

Electronic Breakdown

Intrinsic breakdown occurs in time of the order of 10⁻⁸s and therefore is assumed to be electronic in nature. The initial density of conduction (free) electrons is also assumed to be large, and electron-electron collisions occur.

When an electric field is applied, electrons gain energy from the electric field and cross the forbidden energy gap from the valency to the conduction band. When this process is repeated, more and more electrons become available in the conduction band, eventually leading to breakdown.

Avalanche or Streamer Breakdown

This is similar to breakdown in gases due to cumulative ionization. Conduction electrons gain sufficient energy above a certain critical electric field and cause liberation of electrons from the lattice atoms by collisions.

Under uniform field conditions, if the electrodes are embedded in the specimen, breakdown will occur when an electron avalanche bridges the electrode gap. An electron within the dielectric, starting from the cathode will drift towards the anode and during this motion gains energy from the field and loses it during collisions.

When the energy gained by an electron exceeds the lattice ionization potential, and additional electron will be liberated due to collision of the first electron. This process repeats itself resulting in the formation of an electron avalanche. Breakdown will occur, when the avalanche exceeds a certain critical size.

In practice, breakdown does not occur by the formation of a single avalanche itself, but occurs as a result of many avalanches formed within the dielectric and extending step by step through the entire thickness of the material as shown in Fig.

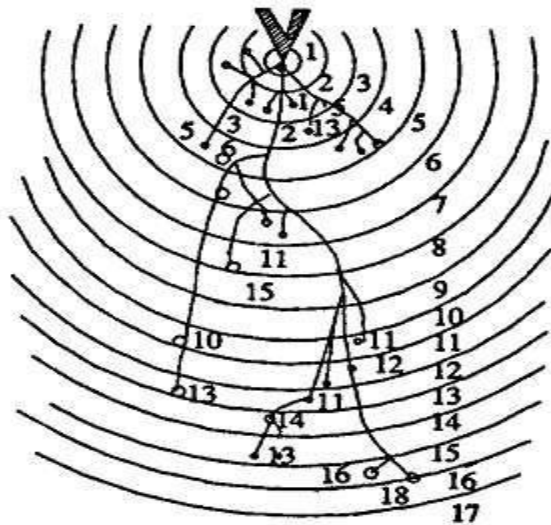

Electromechanical Breakdown

When a dielectric material is subjected to an electric field, charges of opposite nature are induced on the two opposite surfaces of the material and hence a force of attraction is developed and the specimen is subjected to electrostatic compressive forces and when these forces exceed the mechanical withstands strength of the material, the material collapses. If the initial thickness of the material is d_0 and is compressed to a thickness d under the applied voltage V then the compressive stress developed due to electric field is

$$F = \frac{1}{2} \epsilon_0 \epsilon_r \frac{V^2}{d^2}$$

where ϵ_r is the relative permittivity of the specimen. If γ is the Young's modulus, the mechanical compressive strength is

$$\gamma \ln \frac{d_0}{d}$$

Equating the two under equilibrium condition, we have

$$\frac{1}{2} \epsilon_0 \epsilon_r \frac{V^2}{d^2} = \gamma \ln \frac{d_0}{d}$$

or

$$V^2 = d^2 \cdot \frac{2\gamma}{\epsilon_0 \epsilon_r} \ln \frac{d_0}{d} = K d^2 \ln \frac{d_0}{d}$$

Differentiating with respect to d , we have

$$2V \frac{dV}{dd} = K \left[2d \ln \frac{d_0}{d} - d^2 \cdot \frac{d}{d_0} \cdot \frac{d_0}{d^2} \right] = 0$$

or

$$2d \ln \frac{d_0}{d} = d$$

or

$$\ln \frac{d_0}{d} = \frac{1}{2}$$

or

$$\frac{d}{d_0} = 0.6$$

For any real value of voltage V , the reduction in thickness of the specimen can not be more than 40%. If the ratio V/d at this value of V is less than the intrinsic strength of the specimen, a further increase in V shall make the thickness unstable and the specimen collapses. The highest apparent strength is then obtained by substituting $d = 0.6 d_0$ in the above expressions.

$$\frac{V}{d} = \sqrt{\frac{2\gamma}{\epsilon_0 \epsilon_r} \ln 1.67} \quad \text{or} \quad \frac{V}{d_0} = E_a = 0.6 \left[\frac{\gamma}{\epsilon_0 \epsilon_r} \right]^{1/2}$$

The above equation is approximate only as γ depends upon the mechanical stress. The possibility of instability occurring for lower average field is ignored i.e., the effect of stress concentration at irregularities is not taken into account.

Breakdown due to Treeing and Tracking

We know that the strength of a chain is given by the strength of the weakest link in the chain. Similarly whenever a solid material has some impurities in terms of some gas pockets or liquid pockets in it the dielectric strength of the solid will be more or less equal to the strength of the weakest impurities.

The charge concentration there in the void will make the field more non-uniform. The charge concentration in such voids is found to be quite large to give fields of the order of 10 MV/cm which is higher than even the intrinsic breakdown.

These charge concentrations at the voids within the dielectric lead to breakdown step by step and finally lead to complete rupture of the dielectric. Since the breakdown is not caused by a single discharge channel and assumes a tree like structure as shown in Fig. it is known as breakdown due to treeing.

The treeing phenomenon can be readily demonstrated in a laboratory by applying an impulse voltage between point plane electrodes with the point embedded in a transparent solid dielectric such as perspex.

The treeing phenomenon can be observed in all dielectric wherever non-uniform fields prevail. Suppose we have two electrodes separated by an insulating material and the assembly is placed in an outdoor environment.

Some contaminants in the form of moisture or dust particles will get deposited on the surface of the insulation and leakage current starts between the electrode through the contaminants say moisture.

The current heats the moisture and causes breaks in the moisture films. These small films then act as electrodes and sparks are drawn between the films. The sparks cause carbonization

and volatilization of the insulation and lead to formation of permanent carbon tracks on the surface of insulations.

Therefore, tracking is the formation of a permanent conducting path usually carbon across the surface of insulation. For tracking to occur, the insulating material must contain organic substances.. The rate of tracking can be slowed down by adding filters to the polymers which inhibit carbonization.

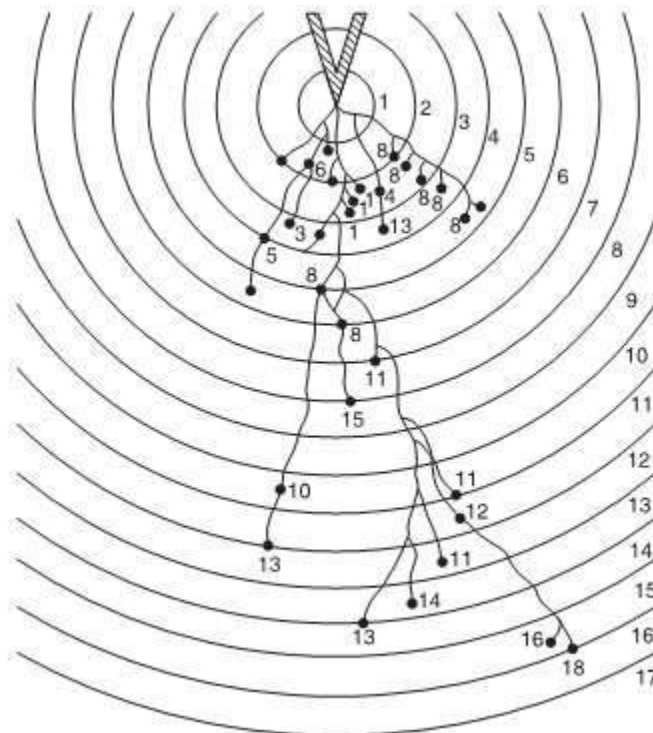

Thermal Breakdown

When an insulating material is subjected to an electric field, the material gets heated up due to conduction current and dielectric losses due to polarization. The conductivity of the material increases with increase in temperature and a condition of instability is reached when the heat generated exceeds the heat dissipated by the material and the material breaks down.

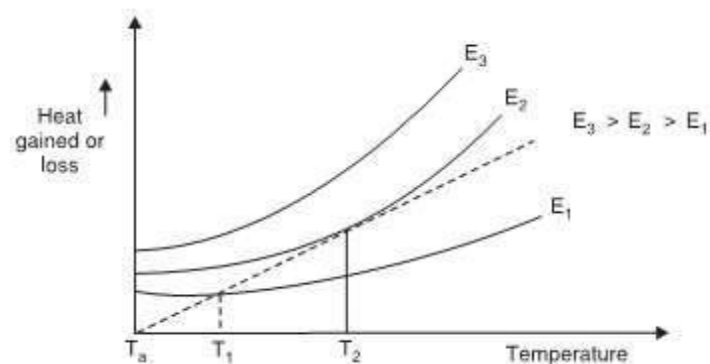

The power required to raise the temperature of the block by ΔT is

$$C_v \frac{dT}{dt} \text{ watts}$$

Therefore,

$$C_v \frac{dT}{dt} + K \frac{d}{dx} \left(\frac{dT}{dx} \right) = \sigma E^2$$

The solution of the above equation will give us the time required to reach the critical temperature T_c for which thermal instability will reach and the dielectric will lose its insulating properties. However, unfortunately the equation can be solved in its present form from C_v, K and ζ are all functions of temperature and in fact ζ may also depend on the intensity of electrical field.

Chemical and Electrochemical Deterioration and Breakdown

In the presence of air and other gases some dielectric materials undergo chemical changes when subjected to continuous electrical stresses. Some of the important chemical reactions that occur are:

Oxidation:

In the presence of air or oxygen, materials such as rubber and polyethylene undergo oxidation giving rise to surface cracks.

Hydrolysis:

When moisture or water vapour is present on the surface of a solid dielectric, hydrolysis occurs and the materials lose their electrical and mechanical properties. Electrical properties of materials such as paper, cotton tape, and other cellulose materials deteriorate very rapidly due to hydrolysis. Plastics like polyethylene undergo changes, and their service life considerably reduces.

Chemical Action:

Even in the absence of electric fields, progressive chemical degradation of insulating materials can occur due to a variety of processes such as chemical instability at high temperatures, oxidation and cracking in the presence of air and ozone, and hydrolysis due to moisture and heat.

Since different insulating materials come into contact with each other in any practical apparatus, chemical reactions occur between these various materials leading to reduction in electrical and mechanical strengths resulting in failure.

The effects of electrochemical and chemical deterioration could be minimized by carefully studying and examining the materials. High soda content glass insulation should be

avoided in moist and damp conditions, because sodium, being very mobile, leaches to the surface giving rise to the formation of a strong alkali which will cause deterioration.

In paper insulation, even if partial discharges are prevented completely, breakdown can occur due to chemical degradation. The chemical and electrochemical deterioration increases very rapidly with temperature, and hence high temperatures should be avoided.

Breakdown Due to Internal Discharges

Solid insulating materials, and to a lesser extent liquid dielectrics contain voids or cavities within the medium or at the boundaries between the dielectric and the electrodes. These voids are generally filled with a medium of lower dielectric strength, and the dielectric constant of the medium in the voids is lower than that of the insulation. Hence, the electric field strength in the voids is higher than that across the dielectric. Therefore, even under normal working voltages the field in the voids may exceed their breakdown value, and breakdown may occur. Let us consider a dielectric between two conductors as shown in Fig. 4.5a. If we divide the insulation into three parts, an electrical network of C_1 , C_2 and C_3 can be formed as shown in Fig. In this C_1 represents the capacitance of the void or cavity, C_2 is the capacitance of the dielectric which is in series with the void, and C_3 is the capacitance of the rest of the dielectric. When the applied voltage is V , the voltage across the void, V_1 is given by the same equation

$$V_1 = \frac{V d_1}{d_1 + \left(\frac{\epsilon_0}{\epsilon_1}\right) d_2}$$

where d_1 and d_2 are the thickness of the void and the dielectric, respectively, having permittivities ϵ_0 and ϵ_1 . Usually $d_1 < d_2$, and if we assume that the cavity is filled with a gas, then

$$V_1 = V \epsilon_r \left(\frac{d_1}{d_2}\right)$$

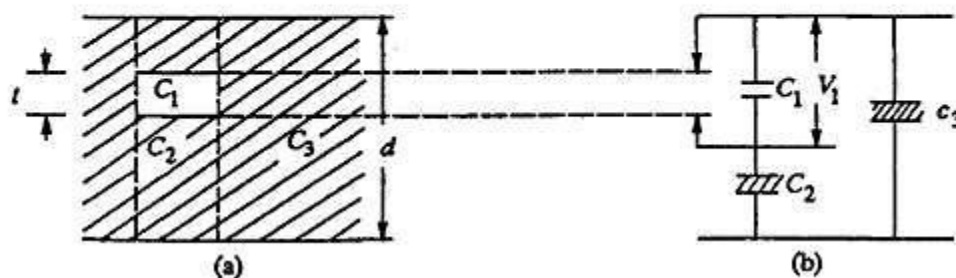

Where ϵ_r is the relative permittivity of the dielectric. When a voltage V is applied, V_1 reaches the breakdown strength of the medium in the cavity (V_j) and breakdown occurs. V_1 is called the 'discharge inception voltage'. When the applied voltage is a.c., breakdown occurs on both the half cycles and the number of discharges will depend on the applied voltage. The voltage and the discharge current waveforms are shown in Fig. .

When the first breakdown across the cavity occurs the breakdown voltage across it becomes zero. When once the voltage V_1 becomes zero, the spark gets extinguished and again the voltage rises till breakdown occurs again. This process repeats again and again, and current pulses as shown, will be obtained both in the positive and negative half cycles.

These internal discharges (also called partial discharges) will have the same effect as "treeing" on the insulation. When the breakdown occurs in the voids, electrons and positive ions are formed. They will have sufficient energy and when they reach the void surfaces they may break the chemical bonds.

Also, in each discharge there will be some heat dissipated in the cavities, and this will carbonize the surface of the voids and will cause erosion of the material. Channels and pits formed on the cavity surfaces increase the conduction.

Chemical degradation may also occur as a result of the active discharge products formed during breakdown. All these effects will result in a gradual erosion of the material and consequent reduction in the thickness of insulation leading to breakdown.

The life of the insulation with internal discharges depends upon the applied voltage and the number of discharges. Breakdown by this process may occur in a few days or may take a few years.

8.Explain the various breakdown mechanism in composite dielectric. (CO2-L1-NOV2014)

BREAKDOWN IN COMPOSITE DIELECTRICS

Properties of Composite Dielectrics

A composite dielectric generally consists of a large number of layers arranged one over the other. This is called "the layered construction" and is widely used in cables, capacitors and transformers. Three properties of composite dielectrics which are important to their performance are given below.

(a) Effect of Multiple Layers

The simplest composite dielectric consists of two layers of the same material. Here, advantage is taken of the fact that two thin sheets have a higher dielectric strength than a single sheet of the same total thickness. The advantage is particularly significant in the case of materials having a wide variation in dielectric strength values measured at different points on its surface.

(b) Effect of Layer Thickness

Increase in layer thickness normally gives increased breakdown voltage. In a layered construction, breakdown channels occur at the interfaces only and not directly through another layer. Also, a discharge having penetrated one layer cannot enter the next layer until a part of the interface also attains the potential which can produce an electric field stress comparable to that of the discharge channel. The use of layered construction is very important in the case of insulating paper since the paper thickness itself varies from point to point and consequently the dielectric strength across its surface is not homogeneous. The differences in the thickness impart a rough surface to the paper which can produce an electric field stress comparable to that of the discharge channel. The rough surface of the paper also helps in better impregnation when tightly wound. On the other hand, the existence of areas with lower thickness in the paper can cause breakdown at these points at considerably lower voltages. Various investigations on composite dielectrics have shown that

- (i) The discharge inception voltage depends on the thickness of the solid dielectric, as well as on the dielectric constant of both the liquid and solid dielectric, and
- (ii) The difference in the dielectric constants between the liquid and solid dielectrics does not significantly affect the rate of change of electric field at the electrode edge with the change in the dielectric thickness.

(c) Effect of Interfaces

The interface between two dielectric surfaces in a composite dielectric system plays an important role in determining its pre-breakdown and breakdown strengths. Discharges usually occur at the interfaces and the magnitude of the discharge depends on the associated surface resistance and capacitance. When the surface conductivity increases, the discharge magnitude also increases, resulting in damage to the dielectric. In a composite dielectric, it is essential to maintain low dielectric losses because they normally operate at high electric stresses. However, even in an initially pure dielectric liquid, when used under industrial conditions for impregnating solid dielectrics, impurities arise, resulting in increased dielectric losses.

Mechanisms of Breakdown in Composite Dielectrics

As mentioned in the earlier section, if dielectric losses are low the cumulative heat produced will be low and thermal breakdown will not occur. However, several other factors can cause short and long time breakdown.

(a) Short-Term Breakdown

If the electric field stresses are very high, failure may occur in seconds or even faster without any substantial damage to the insulating surface prior to breakdown. It has been observed that breakdown results from one or more discharges when the applied voltage is close to the observed breakdown value.

There exists a critical stress in the volume of the dielectric at which discharges of a given magnitude can enter the insulation from the surface and propagate rapidly into its volume to cause breakdown. Experiments with single discharges on an insulating material have shown that breakdown occurs more rapidly when the electric field in the insulation is such that it assists the charged particles in the discharge to penetrate into the insulation, than when the field opposes their entry.

Breakdown was observed to occur more readily when the bombarding particles are electrons, rather than positive ions. In addition, there are local field intensifications due to the presence of impurities and variations in the thickness of solid insulation and these local field intensifications play a very important role in causing breakdown under high field conditions; the actual effect being dependent on the field in the insulation before the discharge impinges on it.

(b) Long-Term Breakdown

Long-term breakdown is also called the ageing of insulation. The principal effects responsible for the ageing of the insulation which eventually leads to breakdown arise from the thermal processes and partial discharges. Partial discharges normally occur within the volume of the composite insulation systems. In addition, the charge accumulation and conduction on the surface of the insulation also contributes significantly towards the ageing and failure of insulation.

(i) Ageing and breakdown due to partial discharges

During the manufacture of composite insulation, gas filled cavities will be present within the dielectric or adjacent to the interface between the conductor and the dielectric. When a voltage is applied to such a system, discharges occur within the gas-filled cavities.

These discharges are called the "partial discharges" and involve the transfer of electric charge between the two points in sufficient quantity to cause the discharge of the local capacitance.

At a given voltage, the impact of this charge on the dielectric surface produces a deterioration of the insulating properties, in many ways, depending on the geometry of the cavity and the nature of the dielectric. The study of breakdown by partial discharges is very important in industrial systems.

The degree of ageing depends on the discharge inception voltage, V_i and the discharge magnitude. It has been shown that V_i is strongly dependent on the permittivity of the dielectric and the thickness of the cavity g . V_i can be estimated approximately by

$$V_i = \left(\frac{E_g}{\epsilon_r} \right) (t + \epsilon_r g)$$

Where E_g is the breakdown stress of the cavity air gap of thickness g and t is the thickness of the dielectric in series with the cavity. For any given arrangement $(g + 1)$ will be constant. Let us call this constant as C . Then, the above equation can be written as

$$V_i = \left(\frac{E_g}{\epsilon_r} \right) [(\epsilon_r - 1)g + C]$$

Differentiating, we get

$$\frac{dV_i}{dg} = \frac{\epsilon_r - 1}{\epsilon_r} \left[E_g + \left\{ g + \frac{C}{\epsilon_r - 1} \right\} \frac{dE}{dg} \right]$$

Here, E_g is always positive and dE/dg is always negative or zero.

In obtaining the above expressions, two assumptions have been made. One is that in the cavity the stress $E_g = \epsilon_r \cdot E$, where E is the electric field across the dielectric. The other is that within the cavity $E_g(\max)/E_g = 1$. When these assumptions are valid, the Paschen law can be used to explain the breakdown of the gas gap (cavity). However, the validity of the above assumptions depends upon the shape and dimensions of the cavity. For the breakdown of the gas in the cavity to occur, the discharge has to start at one end and progress to the other end. As the discharge progresses, the voltage across the cavity drops due to charge accumulation on the cavity surface towards which it is progressing, and often the discharge gets extinguished. The discharge

extinction voltage depends on the conditions inside the cavity. The discharge causes a rise in the temperature and pressure of the gas in the cavity and gaseous deterioration products are also formed. At high frequencies, when the discharges occur very rapidly, these may cause the extinction voltage levels to reach lower values in spite of the erosion of the cavity walls.

From the above analysis the following conclusions can be arrived at

- (i) For very small cavities, V_i decreases as the cavity depth increases, following the Paschen curve of gas breakdown.
- (iii) In spite of the erosion in the cavity walls, breakdown will not occur and the life of the insulation is very long if the applied voltage is less than $2 V_i$.
- (iv) For applied voltages greater than $2V$ corrosion is faster and therefore ageing of the insulation is quicker.
- (v) The total capacitance of the cavity is not discharged as a single event but a result of any discharges, each discharge involving only a small area of the cavity wall determined by the conductivity of the cavity surface in the region of the discharge.

(ii) Ageing and breakdown due to accumulation of charges on insulator surfaces

During discharges at the solid or liquid or solid-gas or solid-vacuum interfaces, certain quantity of charge (electrons or positive ions) gets deposited on the solid insulator surface. The charge thus deposited can stay there for very long durations, lasting for days or even weeks. The presence of this charge increases the surface conductivity thereby increasing the discharge magnitude in subsequent discharges.

Increased discharge magnitude in subsequent discharges causes damage to the dielectric surface. Experiments using electro-photography and other methods have shown that transverse discharges occur on the faces of the dielectric, and these discharges cause a large area to be discharged instantaneously.

Charges that exist in surface conductivity are due to the discharges themselves such that changes in discharge magnitude will occur spontaneously during the life of a dielectric. It has been generally observed that the discharge characteristics change with the life of the insulation.

For clean surfaces, at the discharge inception voltage V/f the discharge characteristic depends on the nature of the dielectric, its size and shape. The discharge normally consists of a large number of comparatively small discharges originating from sites on the insulator surface where the necessary discharge condition exists.

After some time, erosion at these sites causes the discharges to decrease in number as well as in magnitude, and consequently total extinction may occur. With the passage of time, the phenomena involved become complex because the charges from the surface-induced conductivity add to the charge accumulation in the bulk due to partial discharges.

9.Explain the maintenance of oil quality with neat diagram(CO2-L1-NOV2014)

The oil is poured in a container known as test-cell which has internal dimensions of 55 mmX 90 mm× 100 mm high. The electrodes are polished spheres of 12.7 to 13 mm diameter, preferably of brass, arranged horizontally with their axis not less than 40 mm above the bottom of the cell. For the test, the is distance between the spheres shall be $4 + 0.02$ mm. A suitable gauge is used to adjust the gap. While preparing the oil sample, the test-cell should be thoroughly cleaned and the moisture and suspended particles should be avoided. Fig. 1.13 shows an experimental set-up for finding out the dielectric strength of the given sample of oil. The voltmeter is connected on to the primary side of the high voltage transformer but calibrated on the high voltage side.

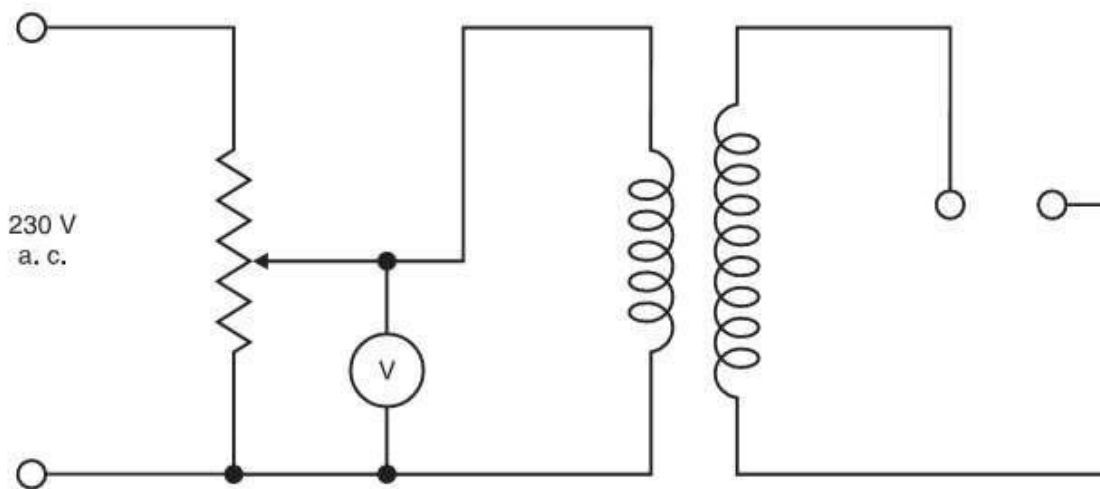

The gap between the spheres is adjusted to 4 mm with the help of a gauge and the spheres are immersed in oil to a depth as mentioned earlier. The voltage is increased gradually and continuously till a flash over of the gap is seen or the MCB operates. Note down this voltage. This voltage is known as rapidly-applied voltage. The breakdown of the gap has taken place mainly due to field effect. The thermal effect is minimal as the time of application is short.

Next bring the voltage back to zero and start with 40% of the rapidly applied voltage and wait for one minute. See if the gap has broken. If not, increase the voltage every time by 2.1/2% of the rapidly applied voltage and wait for one minute till the flash over is seen or the MCB trips. Note down this voltage.

Start again with zero voltage and increase the voltage to a value just obtained in the previous step and wait for a minute. It is expected that the breakdown will take place. A few trials around this point will give us the breakdown value of the dielectric strength.

The acceptable value is 30 kV for 4mm applied for one minute. In fact these days transformer oils with 65 kV for 4 mm 1 minute value are available. If it is less than 30 kV, the oil should be sent for reconditioning.

It is to be noted that if the electrodes are immersed vertically in the oil, the dielectric strength measured may turn out to be lower than what we obtained by placing the electrodes in horizontal position which is the normal configuration.

It is due to the fact that when oil decomposes carbon particles being lighter rise up and if the electrodes are in vertical configuration, these will bridge the gap and the breakdown will take place at a relatively lower value.

Application of Oil in Power Apparatus

Oil is normally used for providing insulation between the live parts of different phases and between phases and the grounded enclosure containing the oil and the main parts of the apparatus. Also it provides cooling effect to the apparatus placed within the enclosure. Besides providing insulation, the oil helps the C.B. to quench the arc produced between the breaker contacts when they begin to separate to eliminate the faulted section from the healthy section of the system.

The temperature about the arc is too high for the three last-named gases to exist and the arc itself runs into a mixture of hydrogen, carbon and copper vapour at temperature above 6000 K. The hydrogen being a diatomic gas gets dissociated into the atomic state which changes the characteristics of the arcon account of its associated change in its thermal conductivity. The outcome of this is that the discharge suddenly contracts and acquires an appreciably higher core temperature. In certain cases, the thermal ionization may be so great that the discharge runs with a lower voltage which may stop the ionization due to the electric field strength. The transition from the field ionization to thermal ionization is most marked in hydrogen and, therefore, in oil circuit breakers.

UNIT III**GENERATION OF HIGH VOLTAGES AND HIGH CURRENTS****PART A****1. Give some uses of HVDC. (CO3-L1-MAY2012)**

Generation of high d.c voltages is mainly required in research work in the areas of pure and applied physics. Sometimes high direct voltages are needed in insulation tests on cables and capacitors. Impulse generator charging units also require HVDC of about 100 to 200 kV. Normally for the generation of dc voltages of up to and the output currents are about 100 mA.

2. What are the applications of impulse current wave forms of high magnitude? (CO3-L1-MAY2012)

Generation of impulse current waveforms of high magnitude (100 kA peak) find application in test work as well as in basic research or non linear resistors, electric arc studies relating to electric plasmas in high current discharges.

3. How are capacitances connected in an impulse current generator? (CO3-L1-MAY2012)

For producing impulse currents of large value a bank of capacitors are connected in parallel and are charged to a specified value and are discharged through a series R.L circuit.

4. What type of wave form will be available in impulse current generator output? (CO3-L1-MAY2012)

Damped wave or damped oscillatory wave.

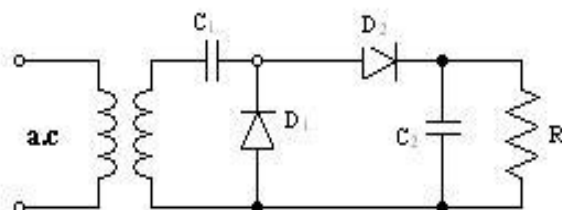
5. Draw a circuit diagram of simple voltage doublers. (CO3-L1-MAY2012)

6. Write the expressions to find the optimum number of stages and % ripple in a voltage multiplier circuits. (CO3-L1-MAY2012)

$$\text{Optimum number of stage} = \sqrt{V_{\text{max}} / f_c // I}$$

$$I = \text{load current and opt \% ripple voltage} = [nI / f_c]$$

7. Draw a simple Tesla Coil equivalent circuit for generation of high frequency A.C high voltage. (CO3-L1-MAY2012)



8. Write an expression to find the % ripple and % voltage regulation in a multi stage voltage multiplier circuit. (CO3-L1-MAY2012)

$$\% \text{ ripple} = \frac{I_l}{n(n+1)}$$

$$\% \text{ regulation} = \frac{I_l}{f_c} \left[\frac{2}{3}n^3 + n^2 - \frac{n}{6} \right]$$

9. Explain the superiority of cascaded transformer over two winding transformer. (CO3-L1-MAY2012)

- Natural cooling is sufficient.
- Transformers are compact in size, so the transportation and assembly is easy.
- Construction is identical.
- Three phase connection in star or delta is possible.

10. An impulse generator has 10 stages with capacitors rated 0.15 μF and 150 kV per stage. The load capacitor is 1000 pf. Find the front and tail resistance to produce an impulse of 1.2 / 50 μs (approximate formula). (CO3-L1-MAY2012)

G.D

Number of stage = 10 solution

$$C_1 = \text{Generator capacitance} = [0.15/10] = 0.015 \mu\text{F}$$

$$C_2 = \text{Load capacitance} = [1000/10^{12}] = 10^{-9} \text{ F}$$

To find Front resistance Front time = 1.2 $\mu\text{ sec}$

$$t_1 = 3 * \text{time constant when neglecting } R_2$$

$$t_1 = 3 * R_1 [C_1 C_2 / C_1 + C_2]$$

$$R_1 = 426.67 \Omega$$

Tail time $t_2 = 50 \mu\text{ sec}$

$$t_2 = 0.7(R_1 + R_2) (C_1 + C_2) \quad R_2 = 4037.63 \Omega$$

11. Define the specification of impulse voltage as per Indian standard. (CO3-L1-MAY2012)

Standard impulse have a rise time of $0.5 \mu s$ and $10 \mu s$ and decay time of 50 % of peak value and of the order of 30 to 200 μs .

12. What is the need for generating impulse currents? (CO3-L1-MAY2012)

Generation of impulse current waveforms of high magnitude find application in testing work as well as in basic research in nonlinear resistors electric arc studies and studies relating to electric plasmas in high current discharges.

13. What is a tesla coil? (CO3-L1-MAY2012)

Tesla coil is a high frequency resonant transformer. It is a doubly tuned resonant circuit as shown in the following figure.



14. What are the factors influencing the measurements using sphere gap? (CO3-L1-MAY2012)

The factors influencing the measurements using sphere gap

- Influence of nearby earthed objects.
- Influence of humidity.
- Influence of dust particles

15. Define the front and tail times of an impulse wave. (CO3-L1-MAY2012)

Referring to wave shape the peak value A is fixed and referred to as 100 % value. The points corresponding to 10 % and 90 % of peak values are located in the front time portion points C & D . The line joining these points is extended to cut the time axis at 0.1. Here 0.1 is taken as the virtual origin. 1.25 times the interval between times t_1 and t_2 corresponding to points C & D is defined as front time $1.25[t_2 - t_1]$. The point E is located on the wave tail corresponding to 50 % of peak value and t_4 is defined as the tail time.

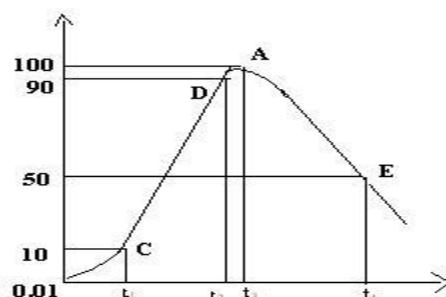

16. What is the necessity for generating high voltages? (CO3-L1-MAY2012)

Applications like electric microscope, X rays, particle accelerators, Electrostatic precipitators etc.

Testing power apparatus.

Insulation testing.

17. What is the principle of Marx circuit? (CO3-L1-MAY2012)

A bank of capacitors are charged in parallel and then discharged in series into a wave shaping network to produce a lightning impulse voltage, double exponential fast rising & slow decaying voltage.

PART B

1. Explain various types of high DC voltage generation with neat diagrams. (CO3-L1-MAY2012)

GENERATION OF HIGH D.C. VOLTAGES

Half and Full Wave Rectifier Circuits

- ✓ Rectifier circuits for producing high D.C. voltages from A.C. sources may be (a) half wave, (b) full wave, or (c) voltage doubler type rectifiers. The rectifier may be an electron tube or a solid state device.
- ✓ Now-a-days single electron tubes are available for peak inverse voltages up to 250 kV, and semiconductor or solid state diodes up to 20 kV.
- ✓ For higher voltages, several units are to be used in series. When a number of units are used in series, transient voltage distribution along each unit becomes non-uniform and special care should be taken to make the distribution uniform.

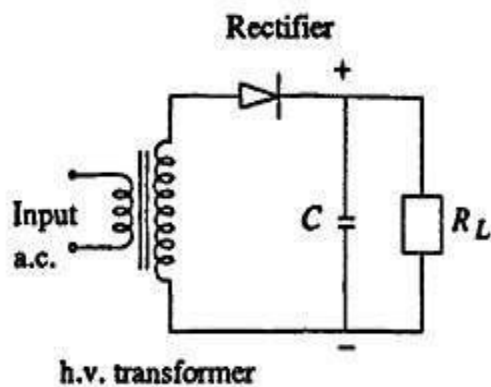

(a) Half wave rectifier

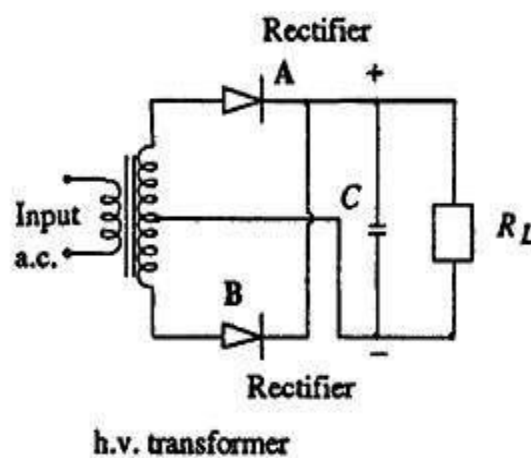

(b) Full wave rectifier

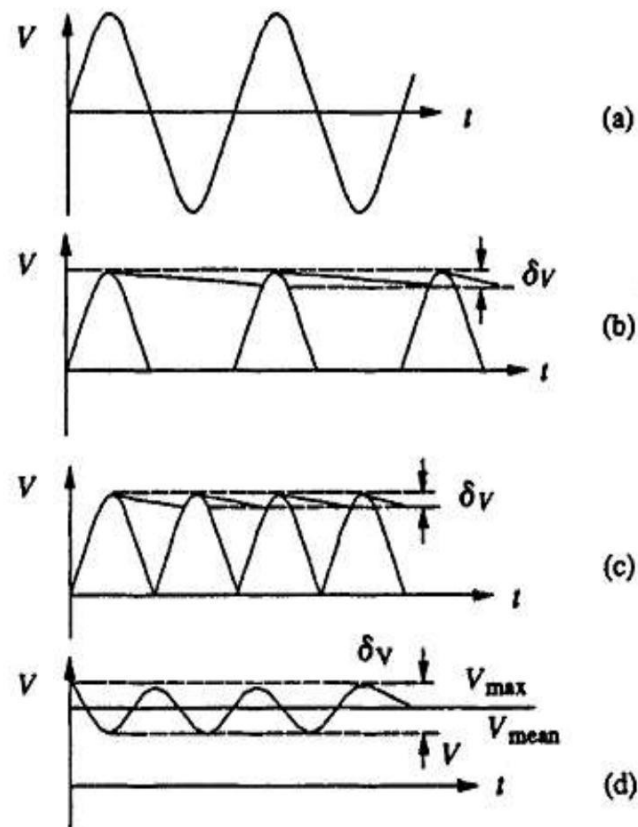

- (a) Input sine wave
 (b) Output with half wave rectifier and condenser filter
 (c) Output with full wave rectifier and condenser filter
 (d) V_{max} , V_{mean} and ripple voltage and δV with condenser filter of a full wave rectifier

- ✓ In the half wave rectifier the capacitor is charged to V_{max} , the maximum a.c. voltage of the secondary of the high voltage transformer in the conducting half cycle. In the other half cycle, the capacitor is discharged into the load.
- ✓ The value of the capacitor C is chosen such that the time constant CR_L is at least 10 times that of the period of the a.c. supply. The rectifier valve must have a peak inverse rating of at least $2V_{max}$. To limit the charging current, an additional resistance R is provided in series with the secondary of the transformer
- ✓ A full wave rectifier circuit is shown in Fig b. In the positive half cycle, the rectifier A conducts and charges the capacitor C , while in the negative half cycle the rectifier B conducts and charges the capacitor.
- ✓ The source transformer requires a center tapped secondary with a rating of $2V$. For applications at high voltages of 50 kV and above, the rectifier valves used are of special construction.

- ✓ Apart from the filament, the cathode and the anode, they contain a protective shield or grid around the filament and the cathode. The anode will be usually a circular plate. Since the electrostatic field gradients are quite large, the heater and the cathode experience large electrostatic forces during the non-conduction periods.
- ✓ To protect the various elements from these forces, the anode is firmly fixed to the valve cover on one side. On the other side, where the cathode and filament are located, a steel mesh structure or a protective grid kept at the cathode potential surrounds them so that the mechanical forces between the anode and the cathode are reflected on the grid structure only.
- ✓ In modern high voltage laboratories and testing installations, semiconductor rectifier stacks are commonly used for producing D.C. voltages. Semiconductor diodes are not true valves since they have finite but very small conduction in the backward direction.
- ✓ The more commonly preferred diodes for high voltage rectifiers are silicon diodes with peak inverse voltage (P.I.V.) of 1 kV to 2 kV. However, for laboratory applications the current requirement is small (a few milliamperes, and less than one ampere) and as such a selenium element stack with P.I.V. of up to 500 kV may be employed without the use of any voltage grading capacitors.
- ✓ Both full wave and half wave rectifiers produce D.C. voltages less than the A.C. maximum voltage. Also, ripple or the voltage fluctuation will be present, and this has to be kept within a reasonable limit by means of filters.

Ripple Voltage with Half Wave and Full Wave Rectifiers

When a full wave or a half wave rectifier is used along with the smoothing condenser C , the voltage on no load will be the maximum A.C. voltage. But when on load, the condenser gets charged from the supply voltage and discharges into load resistance R_L whenever the supply voltage waveform varies from peak value to zero value.

When loaded, a fluctuation in the output D.C. voltage δV appears, and is called a ripple. The ripple voltage δV is larger for a halfwave rectifier than that for a full wave rectifier, since the discharge period in the case of half wave rectifier is larger as shown in Fig..

The ripple δV depends on (a) the supply voltage frequency/, (b) the time constant CR_L and (c) the reactance of the supply transformer X_L . For half wave rectifiers, the ripple frequency is equal to the supply frequency and for full wave rectifiers, it is twice that value.

The ripple voltage is to be kept as low as possible with the proper choice of the filter condenser and the transformer reactance for a given load R_L .

2.Explain the working of voltage doubler circuit with diagrams. (CO3-L1-MAY2012)

Voltage Doubler Circuits:

Both full wave and half wave rectifier circuits produce a d.c. voltage less than the a.c.maximum voltage. When higher d.c. voltages are needed, a voltage doubler or cascaded rectifier doubler circuits are used.

The schematic diagram of voltage doublers are given in Figs. In voltage doubler circuit shown in Fig. 6.3a, the condenser C_1 is charged through rectifier R to a voltage of $+V_{max}$ with polarity as shown in the figure during the negative half cycle. As the voltage of the transformer rises to positive V_{max} during the next half cycle, the potential of the other terminal of C_1 rises to a voltage of $+2V_{max}$.

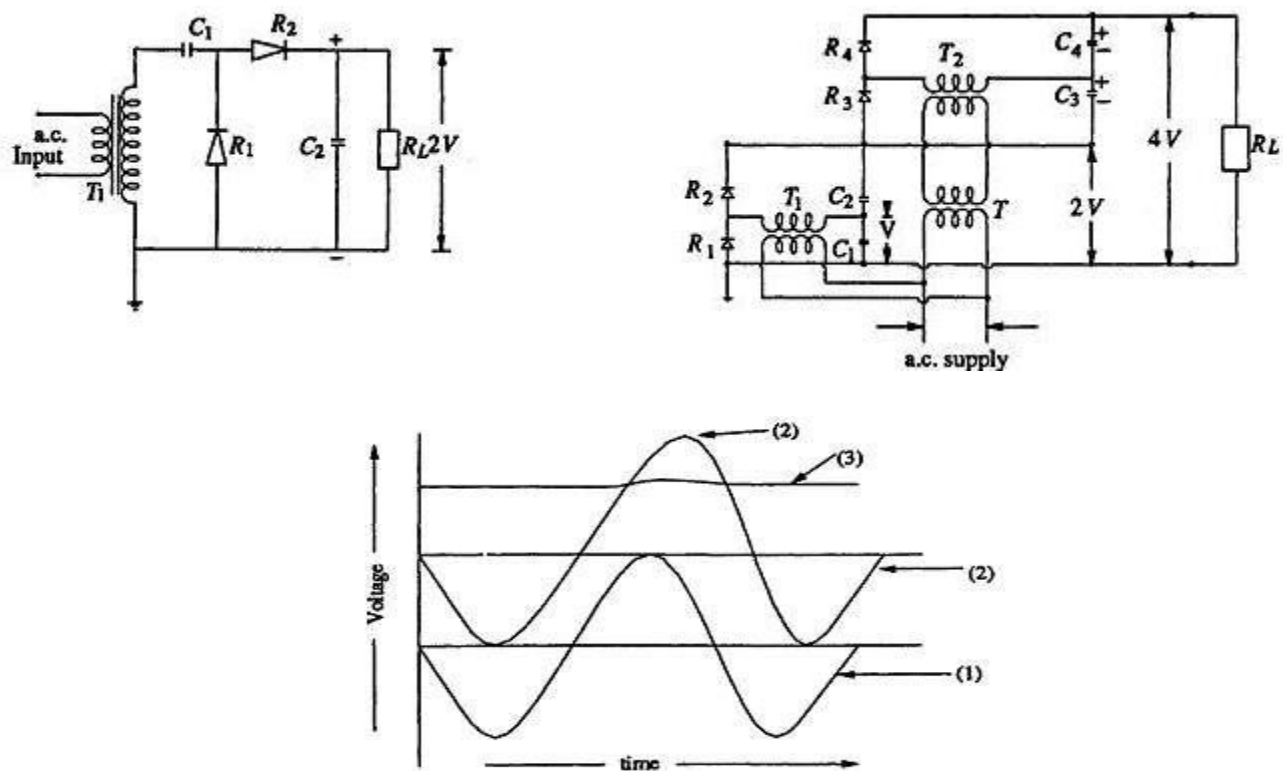

- ✓ Thus, the condenser C_2 in turn is charged through R_2 to $2V_{max}$. Normally the d.c.output voltage on load will be less than $2V_{max}$, depending on the time constant C_2 and the forward charging time constants. The ripple voltage of these circuits will be about 2% for $R_L < 10$ and $XLr < 0.25$, where X and r are the reactance and resistance of the input transformer.

- ✓ The rectifiers are rated to a peak inverse voltage of $2V_{max}$, and the condensers C_1 and C_2 must also have the same rating. If the load current is large, the ripple also is more. Cascaded voltage doublers are used when larger output voltages are needed without changing the input transformer voltage level.
- ✓ A typical voltage doubler is shown in Fig and its input and output waveforms are shown in Fig. The rectifiers R_1 and R_2 with transformer T_1 and condensers C_1 and C_2 produce an output voltage of $2V$ in the same way as described above. This circuit is duplicated and connected in series or cascade to obtain a further voltage doubling to $4V$.
- ✓ T is an isolating transformer to give an insulation for $2K_{max}$ since the transformer T is at a potential of $2V_m$ above the ground. The voltage distribution along the rectifier string R_1, R_2, R_3 and R_4 is made uniform by having condensers C_1, C_2, C_3 and C_4 of equal values.
- ✓ The arrangement may be extended to give $6V, 8V$, and so on by repeating further stages with suitable isolating transformers. In all the voltage doubler circuits, if valves are used, the filament transformers have to be suitably designed and insulated, as all the cathodes will not be at the same potential from ground. The arrangement becomes cumbersome if more than $4V$ is needed with cascaded steps.

3. With a neat circuit explain the working principle of a Cockcroft Walton voltage multiplier circuit.

Cockcroft Walton Voltage Multiplier Circuits

Cascaded voltage multiplier circuits for higher voltages are cumbersome and require too many supply and isolating transformers. It is possible to generate very high d.c. voltages from single supply transformers by extending the simple voltage doubler circuits. This is simple and compact when the load current requirement is less than one milliampere, such as for cathode ray tubes, etc. Valve type pulse generators maybe used instead of conventional a.c. supply and the circuit becomes compact. A typical circuit of this form is shown in fig.

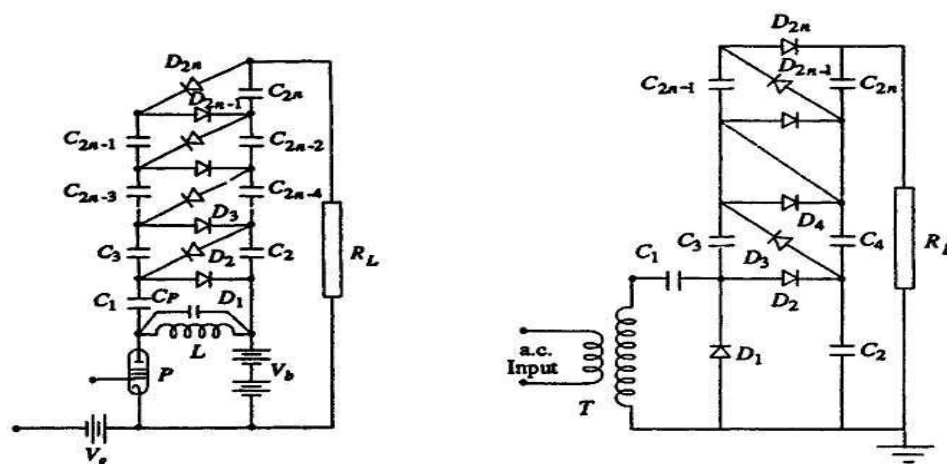

The pulses generated in the anode circuit of the valve P are rectified and the voltage is cascaded to give an output of $2nV_{max}$ across the load R_L . A trigger voltage pulse of triangular waveform (ramp) is given to make the valve switched on and off. Thus, a voltage across the coil L is produced and is equal to $V_{max} = I\sqrt{L}/C_p$ where C_p is the stray capacitance across the coil of inductance L. A d.c. power supply of about 500V applied to the pulse generator, is sufficient to generate a high voltage d.c. of 50 to 100 kV with suitable number of stages. The pulse frequency is high (about 500 to 1000Hz) and the ripple is quite low (<1%). The voltage drop on load is about 5% for load currents of about 150 p, A. The voltage drops rapidly at high load currents.

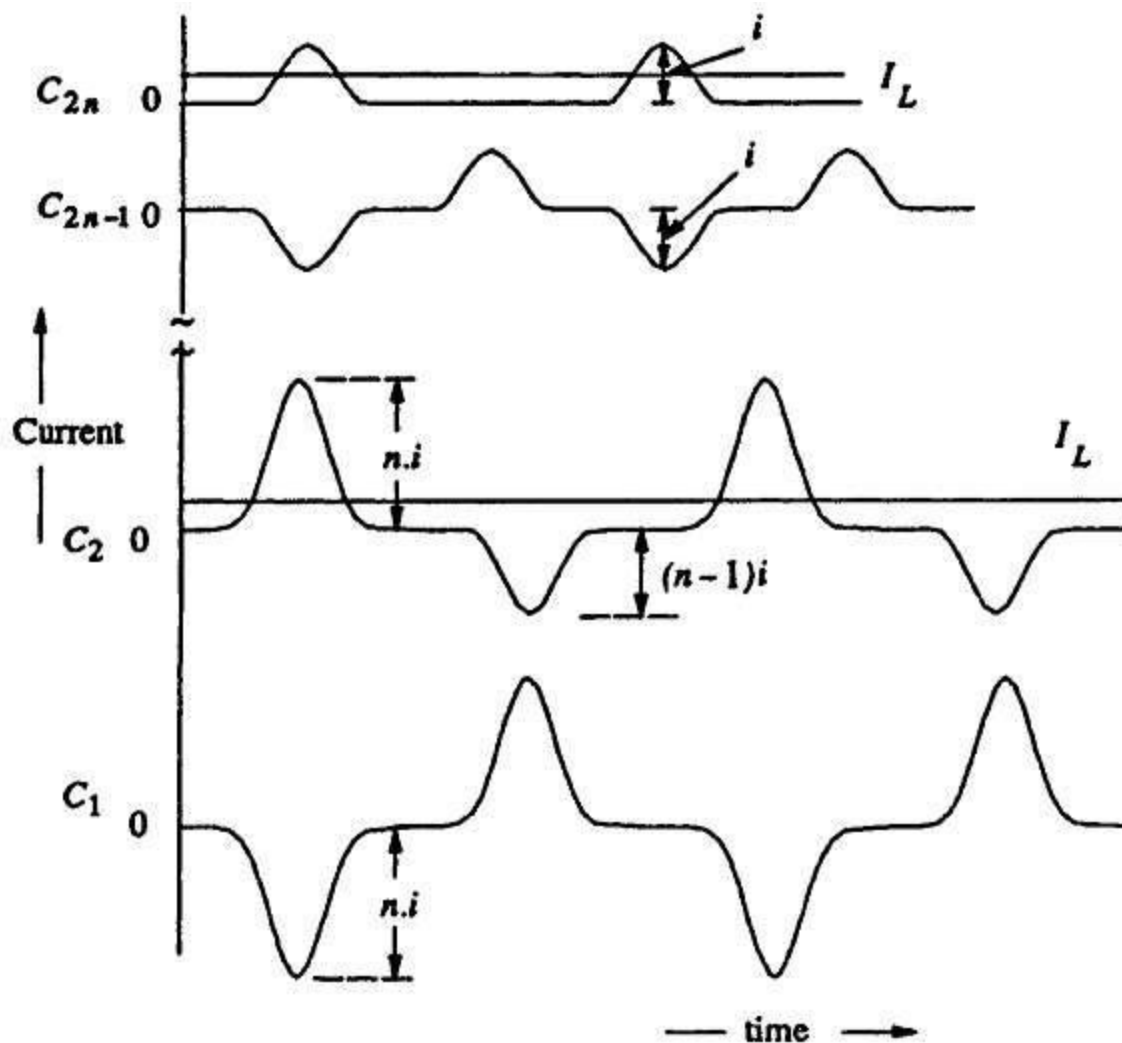

Voltage multiplier circuit using the Cockcroft-Walton principle is shown in Fig..The first stage, i.e. D1, D2, D3, D4, and the transformer T are identical as in the voltage doubler shown in Fig.. For higher output voltage of $4.6, \dots, 2n$ of the input voltage V , the circuit is repeated with cascade or series connection.

Thus, the condenser C_4 is charged to $4V_{max}$ and C_{2n} to $2nV_{max}$ above the earth potential. But the volt across any individual condenser or rectifier is only $2V_{max}$. The rectifiers $D_1, D_3, \dots, D_{2n-1}$ shown in Fig. operate and conduct during the positive half cycles while the rectifiers D_2, D_4, \dots, D_{2n} conduct during the negative half cycles.

Typical current and voltage waveforms of such a circuit are shown in Figs. and respectively. The voltage on C_2 is the sum of the input a.c. voltage, V_{ac} and the voltage across condenser C_1, V_1 as shown in Fig. The mean voltage on C_2 is less than the positive peak charging voltage ($V_{ac} + V_{c1}$).

The voltages across other condensers C_2 to C_{2n} can be derived in the same manner, (i.e.) from the difference between voltage across the previous condenser and the charging voltage. Finally the voltage after $2n$ stages will be $V_{ac} (n_1 + n_2 + \dots)$, where n_1, n_2, \dots are factors when ripple and regulation are considered in the next rectifier. The ripple voltage δV and the voltage drop δV in a cascaded voltage multiplier unit are shown in Fig.

4. With a neat circuit explain the working principle of a Deltatron circuit. (CO3-L1-MAY2012)

Cascaded Modular Voltage Multipliers or "Deltatron" Circuits for Very High Voltages

A combination of Cockcroft-Walton type voltage multiplier with cascaded transformer d.c. rectifier is developed recently for very high voltages but limited output currents having high stability, small ripple factor and fast regulation. One such unit is recently patented by "ENGE" in U.S.A., called "ENGETRON" or "DELTATRON". The schematic diagram of a typical Deltatron unit is shown in Fig.

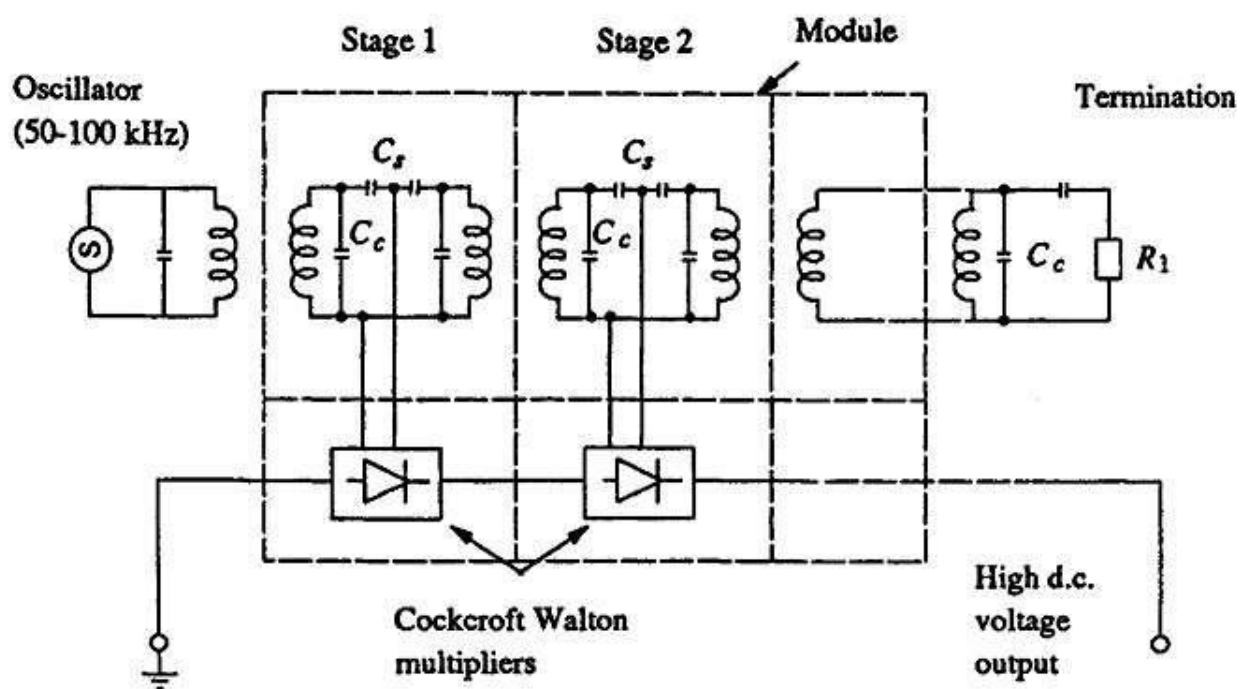

Basically this circuit consists of Cockcroft-Walton multiplier units fed from a supply transformer unit (stage 1). These supply transformers are air-cored to have low inductance and are connected in series through capacitors C. In addition, the windings of the transformers are shunted by a capacitor C to compensate for the magnetizing current. The entire unit is terminated by a load resistor R_1 . All the Cockcroft-Walton multipliers are connected in series and the entire unit is enclosed in a cylindrical vessel insulated by SF_6 gas. Each stage of the unit is typically rated for 10 to 50 W, and about 20 to 25 stages are used in a unit. The whole assembly is usually of smaller size and weight than a cascaded rectifier unit. The supply frequency to the transformers is from a high frequency oscillator (50 to 100 kHz) and as such the capacitors used are of smaller value. The voltage regulation system is controlled by a parallel R-C divider which in turn controls the supply oscillator. Regulation due to load variations or power source voltage variations is very fast (response time < 1 ms). The disadvantage of this circuit is that the polarity of the unit cannot be reversed easily. Typical units of this type may have a rating of 1 MV, 2 mA with each module or stage rated for 50 kV with ripple content less than 1%.

5. Discuss with diagram the operation of Van de Graaff Generators (CO3-L1-MAY2012)

Van de Graaff Generators

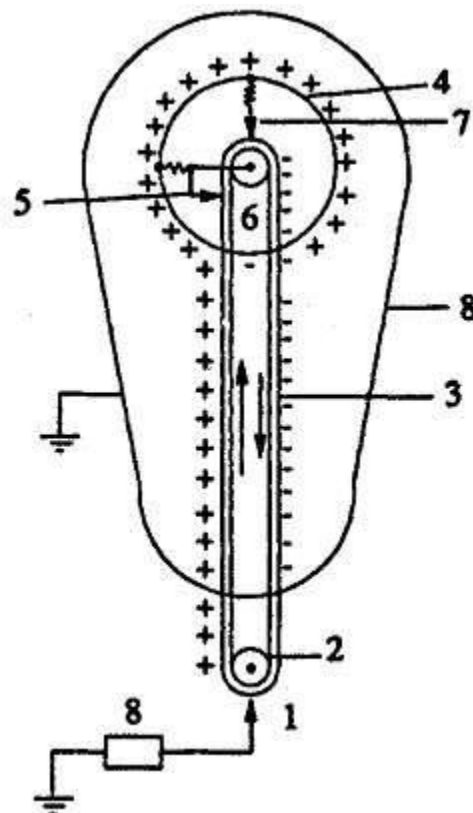

The schematic diagram of a Van deGraaff generator is shown in Fig. The generator is usually enclosed in an earthed metallic cylindrical vessel and is operated under pressure or in vacuum.

Charge is sprayed on to an insulating moving belt from corona points at a potential of 10 to 100 kV above earth and is removed and collected from the belt connected to the inside of an insulated metal electrode through which the belt moves.

The belt is driven by an electric motor at a speed of 1000 to 2000 metres per minute. A steady potential will be attained by the high voltage electrode when the leakage currents and the load current are equal to the charging current.

The shape of the high voltage electrode is so made with re-entrant edges as to avoid high surface field gradients, corona and other local discharges. The shape of the electrode is nearly spherical.

The charging of the belt is done by the lower spray points which are sharp needles and connected to a d.c. source of about 10 to 100 kV, so that the corona is maintained between the moving belt and the needles. The charge from the corona points is collected by the collecting needles from the belt and is transferred on to the high voltage electrode as the belt enters into the high voltage electrode.

The belt returns with the charge dropped, and fresh charge is sprayed on to it as it passes through the lower corona point. Usually in order to make the charging more effective and to utilize the return path of the belt for charging purposes, a self-inducing arrangement or a second corona point system excited by a rectifier inside the high voltage terminal is employed.

To obtain a self-charging system, the upper pulley is connected to the collector needle and is therefore maintained at a potential higher than that of the high voltage terminal.

Thus a second row of corona points connected to the inside of the high voltage terminal and directed towards the pulley above its point of entry into the terminal gives a corona discharge to the belt.

This neutralizes any charge on the belt and leaves an excess of opposite polarity to the terminal to travel down with the belt to the bottom charging point. Thus, for a given belt speed the rate of charging is doubled.

The charging current for unit surface area of the belt is given by $I = bv\delta$, where b is the breadth of the belt in metres, v is the velocity of the belt in m/sec, and δ is the surface charge density in coulombs/m². It is found that δ is $\leq 1.4 \times 10^{-5}$ C/m² to have a safe electric field intensity normal to the surface.

With $b = 3 \text{ m}$ and $v = 3 \text{ m/sec}$, the charging current will be approximately $125 \text{ J}^\mu\text{A}$. The generator is normally worked in a high pressure gaseous medium, the pressure ranging from 5 to 15 atm. The gas may be nitrogen, air, air-freon (CCL_2F_2 mixture), or sulphur hexafluoride (SF_6).

Van de Graaff generators are useful for very high voltage and low current applications. The output voltage is easily controlled by controlling the corona source voltage and the rate of charging.

The voltage can be stabilized to 0.01 %. These are extremely flexible and precise machines for voltage control.

6. Explain the working of Electrostatic Generators (CO3-L1-MAY2012)

Van de Graff generators are essentially high voltage but low power devices, and their power rating seldom exceeds few tens of kilowatts. As such electrostatic machines which effectively convert mechanical energy into electrical energy using variable capacitor principle were developed.

Electrostatic Generators

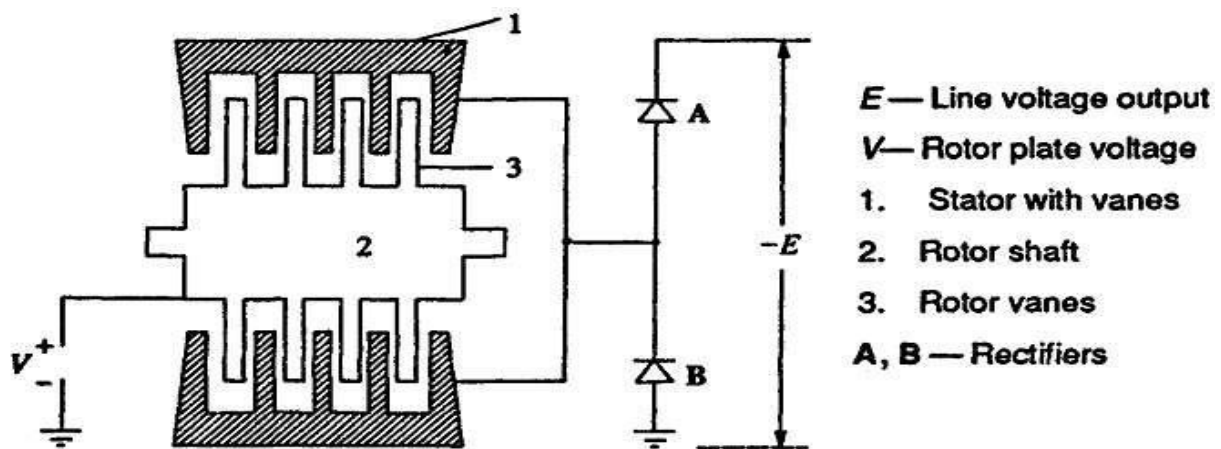

Van de Graff generators are essentially high voltage but low power devices, and their power rating seldom exceeds few tens of kilowatts. As such electrostatic machines which effectively convert mechanical energy into electrical energy using variable capacitor principle were developed. These are essentially duals of electromagnetic machines and are constant voltage variable capacitance machines. An electrostatic generator consists of a stator with interleaved rotor vanes forming a variable capacitor and operates in vacuum applied across the rectifier A and V is applied across C_m . As the rotor rotates, the capacitance C decreases and the voltage across C increases.

Thus, the stator becomes more negative with respect to ground. When the stator reaches the line potential $-E$ the rectifier A conducts, and further movement of the rotor causes the current to flow from the generator. Rectifier B will now have E across it and the charge left in the generator will be

$$Q_0 = C_0 (V+E) + E(C_s + C_r),$$

where C_0 is the stator capacitance to earth, C_r is the capacitance of rectifier B to earth, and C_Q is the minimum capacitance value of C (stator to rotor capacitance). A generator of this type with an output voltage of one MV and a field gradient of 1 MV/cm in high vacuum and having 16 rotor poles, 50 rotor plates of 4 feet maximum and 2 feet minimum diameter, and a speed of 4000 rpm would develop 7 MW of power.

7. With a neat circuit explain the working generation of High AC voltages, impulse voltages.
(CO3-L1-MAY2012)

GENERATION OF HIGH ALTERNATING VOLTAGES

Cascade transformer connection

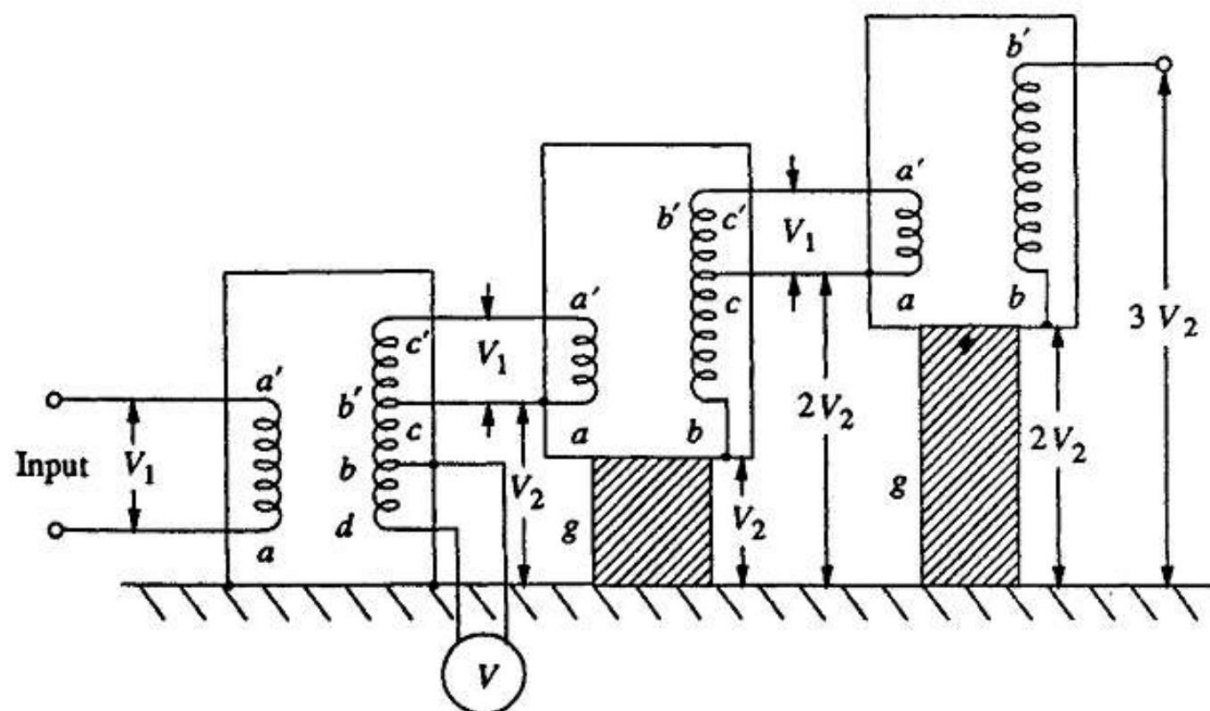

- V_1 — Input voltage
- V_2 — Output voltage
- aa' — L.V. primary winding
- bb' — H.V. secondary winding
- cc' — Excitation winding
- bd — Meter winding (200 to 500 V)

When test voltage requirements are less than about 300 kV, a single transformer can be used for test purposes. The impedance of the transformer should be generally less than 5% and must be capable of giving the short circuit current for one minute or more depending on the design.

In addition to the normal windings, namely, the low and high voltage windings, a third winding known as meter winding is provided to measure the output voltage. For higher voltage requirements, a single unit construction becomes difficult and costly due to insulation problems

These drawbacks are overcome by series connection or cascading of the several identical units of transformers, wherein the high voltage windings of all the units effectively come in series.

Resonant Transformers

The equivalent circuit of a high voltage testing transformer consists of the leakage reactances of the windings, the winding resistances, the magnetizing reactance, and the shunt capacitance across the output terminal due to the bushing of the high voltage terminal and also that of the test object. This is shown in Fig. with its equivalent circuit in Fig. . It may be seen that it is possible to have series resonance at power frequency ω , if $(L_1 + L_2) = 1/\omega^2 C$. With this condition, the current in the test object is very large and is limited only by the resistance of the circuit. The waveform of the voltage across the test object will be purely sinusoidal. The magnitude of the voltage across the capacitance C of the test object will be

$$V_C = \left| \frac{-jVX_C}{R + j(X_L - X_C)} \right| = \frac{V}{R} X_C = \frac{V}{\omega CR}$$

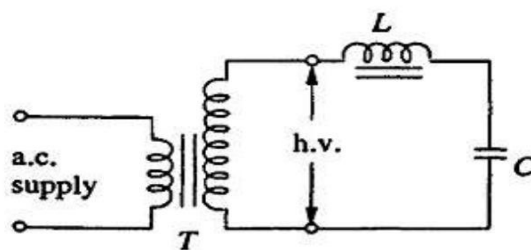

(a)

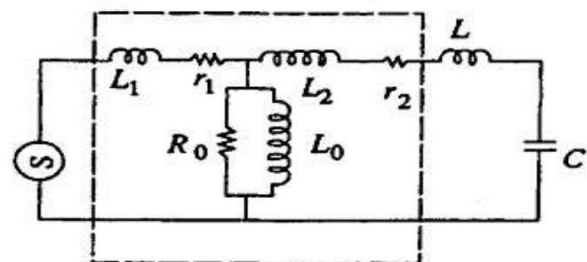

(b)

T — Testing transformer
 L — Choke
 C — Capacitance of h.v. terminal and test object
 L_0 — Magnetizing inductance

L_1, L_2 — Leakage inductances of the transformer
 r_1, r_2 — Resistances of the windings
 R_0 — Resistance due to core loss

The factor $X_c/R = 1/(\omega CR)$ is the Q factor of the circuit and gives the magnitude of the voltage multiplication across the test object under resonance conditions. Therefore, The input voltage required for excitation is reduced by a factor $1/Q$, and the output kVA required is also reduced by a factor $1/Q$. The secondary power factor of the circuit is unity.

This principle is utilized in testing at very high voltages and on occasions requiring large current outputs such as cable testing, dielectric loss measurements, partial discharge measurements, etc.

A transformer with 50 to 100 kV voltage rating and a relatively large current rating is connected together with an additional choke, if Excitation transformer Regulator Load capacitance Reactor Series resonant a.c. test system Excitation transformer Regulator Load capacitance Reactor necessary.

The test condition is set such that $G(L_e + L) = 1/c\omega C$ where L_e is the total equivalent leakage inductance of the transformer including its regulating transformer. The chief advantages of this principle are:

- (a) it gives an output of pure sine wave,
- (b) power requirements are less (5 to 10% of total kVA required),
- (c) no high-power arcing and heavy current surges occur if the test object fails, as resonance ceases at the failure of the test object,
- (d) cascading is also possible for very high voltages,
- (e) simple and compact test arrangement, and
- (f) No repeated flashovers occur in case of partial failures of the test object and insulation recovery. It can be shown that the supply source takes Q number of cycles at least to charge the test specimen to the full voltage.

Generation of High Frequency a.c. High Voltages

High frequency high voltages are required for rectifier d.c. power supplies as discussed in Sec. 6.1. Also, for testing electrical apparatus for switching surges, high frequency high voltage damped oscillations are needed which need high voltage high frequency transformers. The advantages of these high frequency transformers are:

- (i) the absence of iron core in transformers and hence saving in cost and size,
- (ii) pure sine wave output,
- (iii) slow build-up of voltage over a few cycles and hence no damage due to switching surges,
- (iv) uniform distribution of voltage across the winding coils due to sub division of coil stack into a number of units.

The commonly used high frequency resonant transformer is the Tesla coil, which is a doubly tuned resonant circuit shown schematically in Fig. 6.13a. The primary voltage rating is 10 kV and the secondary may be rated to as high as 500 to 1000 kV. The primary is fed from a d.c. or a.c. supply through the condenser C_1 .

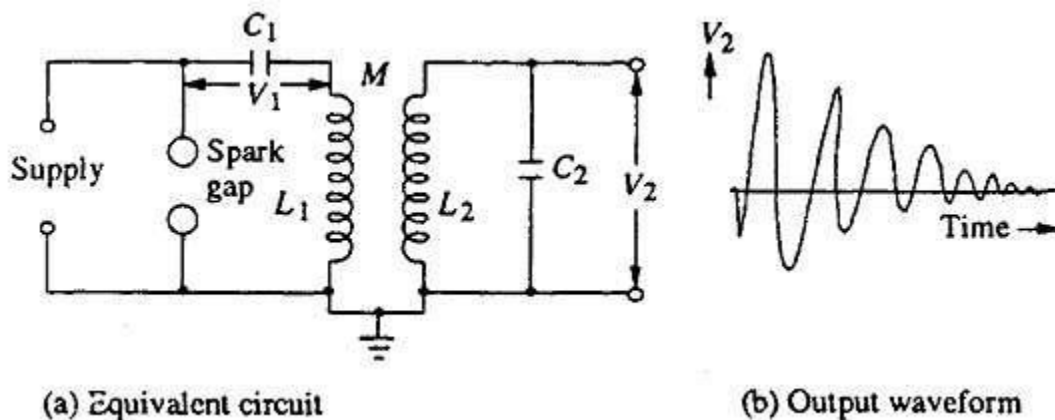

A spark gap G connected across the primary is triggered at the desired voltage V_2 which induces a high self-excitation in the secondary. The primary and the secondary windings (L_1 and L_2) are wound on an insulated former with no core (air-cored) and are immersed in oil. The windings are tuned to a frequency of 10 to 100 kHz by means of the condensers C_1 and C_2 . The output voltage V_2 is a function of the parameters L_1 , L_2 , C_1 , C_2 and the mutual inductance M . Usually, the winding resistances will be small and contribute only for damping of the oscillations

The analysis of the output waveform can be done in a simple manner neglecting the winding resistances. Let the condenser C_1 be charged to a voltage V_1 when the spark gap is triggered. Let a current i_1 flow through the primary winding L_1 and produce a current i_2 through L_2 and C_2

Then,

$$V_1 = \frac{1}{C_1} \int_0^t i_1 dt + L_1 \frac{di_1}{dt} + M \frac{di_2}{dt}$$

and,

$$0 = \frac{1}{C_2} \int_0^t i_2 dt + L_2 \frac{di_2}{dt} + M \frac{di_1}{dt}$$

The Laplace transformed equations for the above are,

$$\frac{V_1}{s} = \left[L_1 s + \frac{1}{C_1 s} \right] I_1 + M s I_2$$

and,

$$0 = [M s] I_1 + \left[L_2 s + \frac{1}{C_2 s} \right] I_2$$

where I_1 and I_2 are the Laplace transformed values, of i_1 and i_2 .

The output voltage V_2 across the condenser C_2 is

$$V_2 = \frac{1}{C_2} \int_0^t i_2 dt; \text{ or its transformed equation is}$$

$$V_2(s) = \frac{I_2}{C_2 s}$$

where $V_2(s)$ is the Laplace transform of V_2 .

The solution for V_2 from the above equations will be

$$V_2 = \frac{M V_1}{\sigma L_1 L_2 C_1} \frac{1}{\gamma_2^2 - \gamma_1^2} [\cos \gamma_1 t - \cos \gamma_2 t]$$

where,

$$\sigma^2 = 1 - \frac{M^2}{L_1 L_2} = 1 - K^2$$

K = coefficient of coupling between the windings L_1 and L_2

$$\gamma_{1,2} = \frac{\omega_1^2 + \omega_2^2}{2} \pm \sqrt{\left(\frac{\omega_1^2 + \omega_2^2}{2} \right)^2 - \omega_1^2 \omega_2^2 (1 - K^2)}$$

$$\omega_1 = \frac{1}{\sqrt{L_1 C_1}} \text{ and } \omega_2 = \frac{1}{\sqrt{L_2 C_2}}$$

The peak amplitude of the secondary voltage V_2 can be expressed as,

$$V_{2\max} = V_1 e \sqrt{\frac{L_2}{L_1}}$$

where,

$$e = \frac{2\sqrt{1-\sigma}}{\sqrt{(1+a)^2 - 4\sigma a}}$$

$$a = \frac{L_2 C_2}{L_1 C_1} = \frac{W_1^2}{W_2^2}$$

A more simplified analysis for the Tesla coil may be presented by considering that the energy stored in the primary circuit in the capacitance C_1 is transferred to C_2 via the magnetic coupling. If W_1 is the energy stored in C_1 and W_2 is the energy transferred to C_2 and if the efficiency of the transformer is η , then

$$W_1 = \frac{1}{2} \eta C_1 V_1^2 = \left(\frac{1}{2} C_2 V_2^2\right)$$

$$V_2 = V_1 \sqrt{\eta \frac{C_1}{C_2}}$$

It can be shown that if the coefficient of coupling K is large the oscillation frequency is less, and for large values of the winding resistances and K , the waveform may become a unidirectional impulse. This is shown in the next sections while dealing with the generation of switching surges

GENERATION OF IMPULSE VOLTAGES

Standard Impulse Wave shapes

Transient over voltages due to lightning and switching surges cause steep build-up of voltage on transmission lines and other electrical apparatus. Experimental investigations showed that these waves have a rise time of 0.5 to 10 μ s and decay time to 50% of the peak value of the order of 30 to 200 μ s. The waveshapes are arbitrary, but mostly unidirectional. It is shown that lightning overvoltage wave can be represented as double exponential waves defined by the equation

$$V = V_0 [\exp(-\alpha t) - \exp(-\beta t)]$$

where α and β are constants of microsecond values.

The above equation represents a unidirectional wave which usually has a rapid rise to the peak value and slowly falls to zero value. The general wave shape is given in Fig. Impulse waves are specified by defining their rise or front time, fall or tail time to 50% peak value, and the value of the peak voltage.

Thus 1.2/50 μ s, 1000 kV wave represents an impulse voltage wave with a front time of 1.2 μ s, fall time to 50% peak value of 50 μ s, and a peak value of 1000 kV. When impulse wave shapes are recorded, the initial portion of the wave will not be clearly defined or sometimes will be missing. Moreover, due to disturbances it may contain superimposed oscillations in the rising portion. Hence, the front and tail times have to be defined.

Referring to the wave shape in the peak value A is fixed and referred to as 100% value. The points corresponding to 10% and 90% of the peak values are located in the front portion (points C and D). The line joining these points is extended to cut the time axis at O_1 . O_1 is taken as the virtual origin. 1.25 times the interval between times t_1 and t_2 corresponding to points C and D (projections on the time axis)

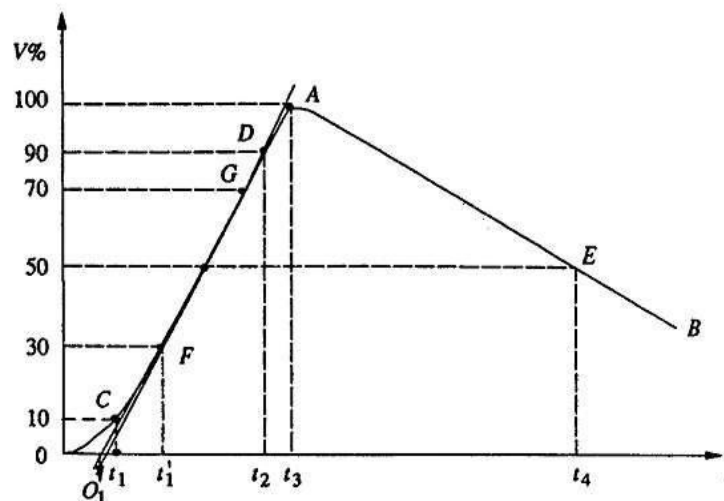

8. With neat diagram explain the working of Marx circuit Multistage Impulse Generators— Marx Circuit

The schematic diagram of Marx circuit and its modification are shown in Figs. respectively. Usually the charging resistance R_s is chosen to limit the charging current to about 50 to 100 mA, and the generator capacitance C is chosen such that the product CR_s is about 10 s to 1 min.

The gap spacing is chosen such that the breakdown voltage of the gap G is greater than the charging voltage V . Thus, all the capacitances are charged to the voltage V in about 1 minute. When the impulse generator is to be discharged, the gaps G are made to spark over simultaneously by some external means. Thus, all the capacitors C get connected in series and discharge into the load capacitance or the test object.

The discharge time constant CR/n (for n stages) will be very small (microseconds), compared to the charging time constant CR_s which will be few seconds. Hence, no discharge takes place through the charging resistors R_s .

In the Marx circuit is of Fig. the impulse wave shaping circuit is connected externally to the capacitor unit. In Fig., the modified Marx circuit is shown, wherein the resistances R_1 and R_2 are incorporated inside the unit. R_1 is divided into n parts equal to R_1/n and put in series with the gap G .

R2 is also divided into n parts and arranged across each capacitor unit after the gap G. This arrangement saves space, and also the cost is reduced. But, in case the wave shape isto be varied widely, the variation becomes difficult.

The additional advantages gained by distributing R1 and R2 inside the unit are that the control resistors are smaller in size and the efficiency (V_o/nv) are high. Impulse generators are nominally rated by the total voltage (nominal), the number of stages, and the gross energy stored. The nominal output voltage is the number of stages multiplied by the charging voltage

. The nominal energy stored is given by $\frac{1}{2}nC_1V^2$ where $C_1 = C_1/n$ (the discharge capacitance) and V is the nominal maximum voltage (n times charging voltage). A 16-stage impulse generator having a stagecapacitance of $0.280 \mu F$ and a maximum charging voltage of 300 kV will have anenergy rating of 192 kW sec.

The height of the generator will be about 15 m and willoccupy a floor area of about 3.25 x 3.00 m. The waveform of either polarity can be obtained by suitably changing the charging unit polarity.

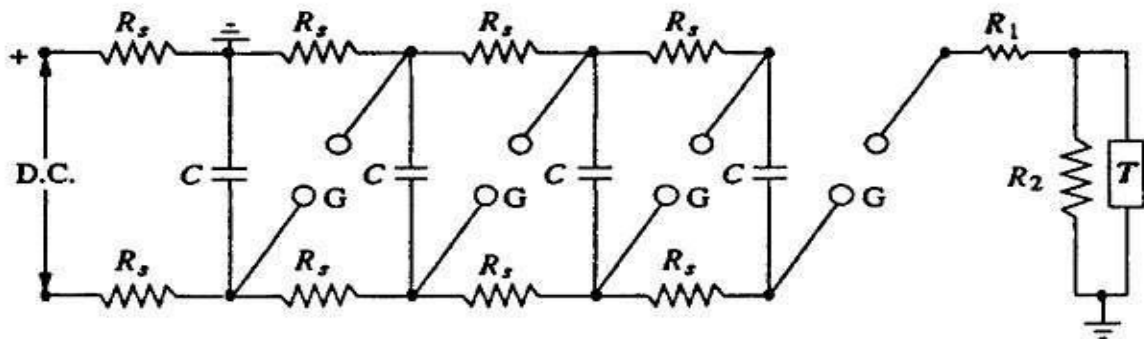

- C — Capacitance of the generator
- R_s — Charging resistors
- G — Spark gap
- R_1, R_2 — Wave shaping resistors
- T — Test object

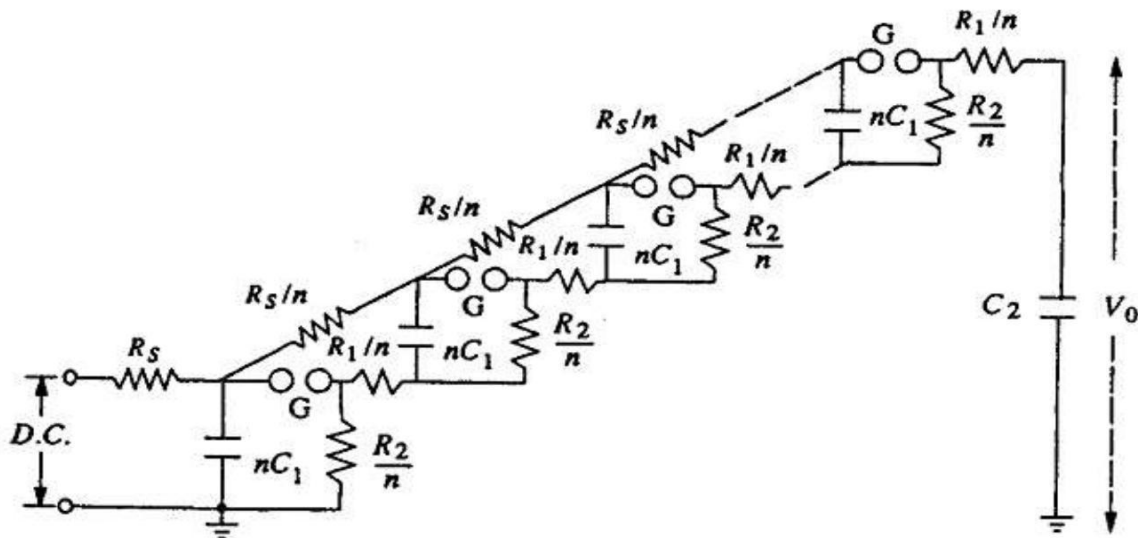

Components of a Multistage Impulse Generator

(i) D.C. Charging Set

The charging unit should be capable of giving a variable d.c. voltage of either polarity to charge the generator capacitors to the required value.

(ii) Charging Resistors

These will be non-inductive high value resistors of about 10 to 100 kilo-ohms. Each resistor will be designed to have a maximum voltage between 50 and 100 kV. (iii) Generator

Capacitors and Spark Gaps

These are arranged vertically one over the other with all the spark gaps aligned. The capacitors are designed for several charging and discharging operations. On dead short circuit, the capacitors will be capable of giving 10 kA of current. The spark gaps will be usually spheres or hemispheres of 10 to 25 cm diameter. Sometimes spherical ended cylinders with a central support may also be used. (iv) Wave-shaping Resistors and Capacitors

Resistors will be non-inductive wound type and should be capable of discharging impulse currents of 1000 A or more. Each resistor will be designed for a maximum voltage of 50 to 100 kV. The resistances are bifilar wound or non-inductive thin flat insulating sheets. In some cases, they are wound on thin cylindrical formers and are completely enclosed. The load capacitor may be of compressed gas or oil filled with a capacitance of 1 to 10 μf . Modern impulse generators have their wave-shaping resistors included internally with a flexibility to add additional resistors outside, when the generator capacitance is changed (with series parallel connection to get the desired energy rating at a given test voltage). Such generators optimize the set of resistors. A commercial impulse voltage generator uses six sets of resistors ranging from 1.0 ohm to about 160 ohms with different combinations (with a maximum of two resistors at a time) such that a resistance value varying from 0.7 ohm to 235 ohms per stage is obtained, covering a very large range of energy and test voltages. The resistors used are usually resin cast with voltage and energy ratings of 200 to 250 kV and 2.0 to 5.0 kWsec. The entire range of lightning and switching impulse voltages can be covered using these resistors either in series or in parallel combination. (v) Triggering System This consists of trigger spark gaps to cause spark breakdown of the gaps (vi) Voltage Dividers

Voltage dividers of either damped capacitor or resistor type and an oscilloscope with recording arrangement are provided for measurement of the voltages across the test object. Sometimes a sphere gap is also provided for calibration purposes

9. With neat diagram explain the working of generation of Impulse Currents. (CO3-L1-MAY2012)

GENERATION OF IMPULSE CURRENTS

Lightening discharges involve both high voltage impulses and high current impulses on transmission lines. Protective gear like surge diverters have to discharge the lightning currents without damage. Therefore, generation of impulse current waveforms of high magnitude ($\ll 100$ kA peak) find application in testing work as well as in basic research on non-linear resistors, electric arc studies, and studies relating to electric plasmas in high current discharges.

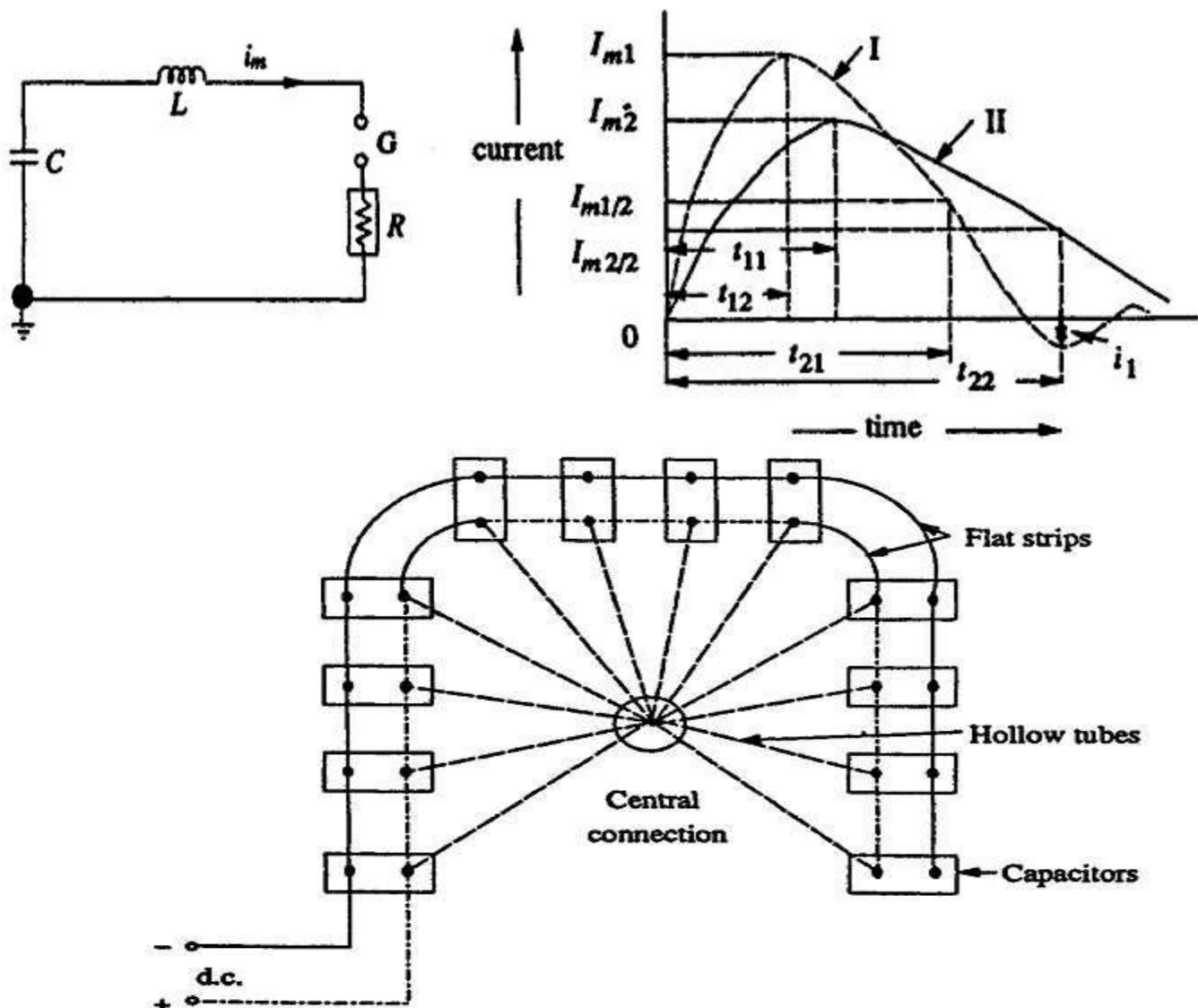

For producing impulse currents of large value, a bank of capacitors connected in parallel are charged to a specified value and are discharged through a series R-L circuit as shown in Fig. represents a bank of capacitors connected in parallel which are charged from a d.c. source to a voltage up to 200 kV. R represents the dynamic resistance of the test object and the resistance of the circuit and the shunt L is an air cored high current inductor, usually a spiral tube of a few turns. If the capacitor is charged to a voltage V and discharged when the spark gap is triggered, the current it will be given by the equation

$$V = R i_m + L \frac{di_m}{dt} + \frac{1}{C} \int_0^t i_m dt$$

The circuit is usually underdamped, so that

$$\frac{R}{2} < \sqrt{L/C}$$

Hence, i_m is given by

$$i_m = \frac{V}{\omega L} [\exp(-\alpha t)] \sin(\omega t)$$

where

$$\alpha = \frac{R}{2L} \text{ and } \omega = \sqrt{\frac{1}{LC} - \frac{R^2}{4L^2}}$$

The time taken for the current i_m to rise from zero to the first peak value is

$$t_1 = t_f = \frac{1}{\omega} \sin^{-1} \frac{\omega}{\sqrt{LC}} = \frac{1}{\omega} \tan^{-1} \frac{\omega}{\alpha}$$

The duration for one half cycle of the damped oscillatory wave t_2 is,

$$t_2 = \frac{\pi}{\sqrt{\frac{1}{LC} - \frac{R^2}{4L^2}}}$$

10. With neat diagram explain the working of tripping and control of impulse generators (CO3-L1-MAY2012)

TRIPPING AND CONTROL OF IMPULSE GENERATORS

In large impulse generators, the spark gaps are generally sphere gaps or gaps formed by hemispherical electrodes.

The gaps are arranged such that sparking of one gap results in automatic sparking of other gaps as overvoltage is impressed on the other. In order to have consistency in sparking, irradiation from an ultra-violet lamp is provided from the bottom to all the gaps.

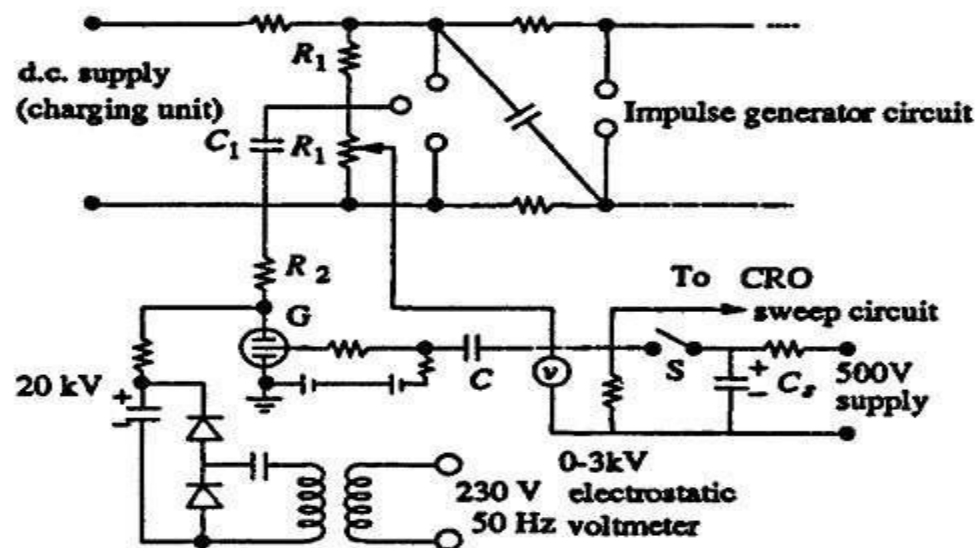

To trip the generator at a predetermined time, the spark gaps may be mounted on a movable frame, and the gap distance is reduced by moving the movable electrodes closer. This method is difficult and does not assure consistent and controlled tripping.

A simple method of controlled tripping consists of making the first gap a three electrode gap and firing it from a controlled source. Figure gives the schematic arrangement of a three electrode gap. The first stage of the impulse generator is fitted with a three electrode gap, and the central electrode is maintained at a potential in between that of the top and the bottom electrodes with the resistors R_1 and R_2 .

The tripping is initiated by applying a pulse to the thyatron G by closing the switch S. The capacitor C produces an exponentially decaying pulse of positive polarity. The pulse goes and initiates the oscillograph time base. The thyristor conducts on receiving the pulse from the switch S and produces a negative pulse through the capacitance C_1 at the central electrode of the three electrode gap. Hence, the voltage between the central electrode and the top electrode of the three electrode gap goes above its sparking potential and thus the gap conducts. The time lag required for the thyatron firing and breakdown of the three electrode gap ensures that the sweep circuit of the oscillograph coupling of voltage oscillations produced at the spark gap entering the oscilloscope through the common trip circuit

.The three electrode gap requires larger space and an elaborate construction. Now-a-days a trigatron gap shown in Fig. is used, and this requires much smaller voltage for operation compared to the three electrode gap.

A trigatron gap consists of a high voltage spherical electrode of suitable size, an earthed main electrode of spherical shape, and a trigger electrode through the main electrode. The trigger electrode is a metal rod with an annular clearance of about 1 mm fitted into the main electrode through a bushing.

The trigatron is connected to a pulse circuit as shown in figure. Tripping of the impulse generator is effected by a trip pulse which produces a spark between the trigger electrode and the earthed sphere. Due to space charge effects and distortion of the field in the main gap, spark over of the main gap

Three Electrode Gap for Impulse Current Generator

In the case of impulse current generators using three electrode gaps for tripping and control, a certain special design is needed. The electrodes have to carry high current from the capacitor bank. Secondly, the electrode has to switch large currents in a small duration of time (in about a microsecond).

Therefore, the switch should have very low inductance. The erosion rate of the electrodes should be low. For high current capacitor banks, a number of spark gap switches connected in parallel as shown in Fig. are often used to meet the requirement.

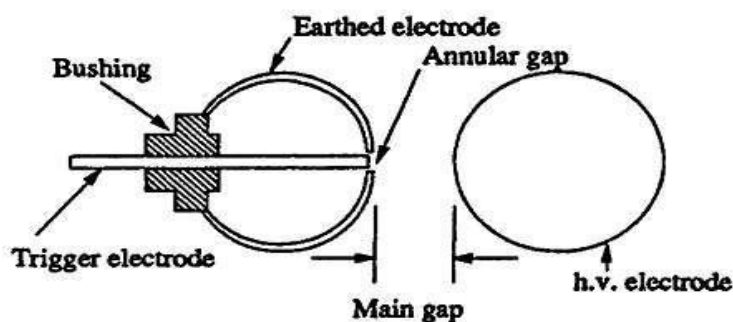

Recently, trigatron gaps are being replaced by triggered vacuum gaps, the advantage of the latter being fast switching at high currents (> 100 kA) in a few nanoseconds. Triggering of the spark gaps by focused laser beams is also adopted since the performance is better than the conventional triggering methods.

UNIT IV**MEASUREMENT OF HIGH VOLTAGES AND HIGH CURRENTS****PART A**

- 1. What are the general methods used for measurement of high frequency and impulse currents? (CO4-L1-MAY2011)**

The following methods used for measurement of high frequency and impulse currents

- Potential divider with a cathode ray oscilloscope.
- Peak voltmeters.
- Sphere gaps

- 2. What is the high voltage d.c measurement techniques used? (CO4-L1-MAY2011)**

The following techniques are used for measurement of high voltage dc.

- Series resistance micro ammeter
- Resistance potential-divider
- Generating voltmeter
- Sphere and other spark gaps

- 3. For what measurement are Hall generators normally used? (CO4-L1-MAY2011)**

These are used for measurement of high direct currents. It can be used for measurement of unidirectional a.c impulse current also.

- 4. What type of measuring devices are preferred for measurement of Impulse currents of short duration? (CO4-L1-MAY2011)**

Park's tubular shunt (or) coaxial tube is preferred for measurement of impulse current of short duration.

- 5. Draw the simple circuit of peak reading voltmeter and its equivalent. (CO4-L1-MAY2011)**

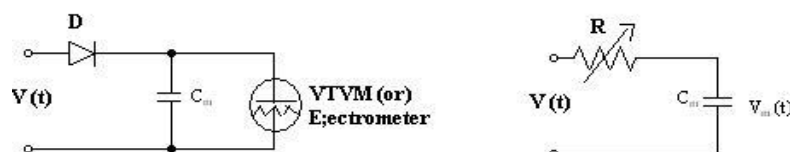

- 6. List the factors that are influencing the peak voltage measurement using sphere gap. (CO4-L1-MAY2011)**

The following are the factors

- Nearby earthed objects
- Atmospheric conditions and humidity
- Radiation
- Polarity and rise time voltage of waveforms.

7. What are the advantages of CVT measurement in HVAC? (CO4-L1-MAY2011)

- a) Simple design and easy installation
- b) Can be used both as a voltage measuring device for meter and relaying purpose and as a coupling condenser for power line carrier communication and relaying
- c) Frequency independent voltage distribution along elements as against conventional magnetic potential transformer which require additional insulation design
- d) Provides isolation between the high voltage terminal and low voltage testing.

8. Why do we resort to statistical approach during breakdown due to impulse voltage? (CO4-L1-MAY2011)

The test is done with the specified voltage usually the probability failure is 40 % and 60 % failure values or 0 % and 80 % value since it is difficult to adjust the test for the exact 50 % flashover values. The average value of upper and lower limit is taken.

9. State the demerits of CVT measurement for HVAC measurements. (CO4-L1-MAY2011)

- a) Voltage ratio is susceptible to temperature variations.
- b) In the presence of capacitance and choke, the problem of ferro-resonance occurs in power system.

10. What are high current shunts mention their design criterion? (CO4-L1-MAY2011)

The most common method employed for high impulse current is a low ohmic pure resistive shunt. The resistance shunt is usually designed in the following manner to reduce the stray effects.

- a) Bifilar flat strip design
- b) Coaxial cable or parts shunt design
- c) Coaxial squirrel cage design.

11. Why are capacitive voltage dividers preferred for AC high voltage measurements? (CO4-L1-MAY2011)

The high voltage dividers are preferred for high ac voltage measurement because the capacitance ratio is independent of frequency.

12. Calculate the correction factors for atmospheric conditions, if the laboratory temperatures is 37°C, the atmospheric pressure is 750 mm Hg and the wet bulb temperature is 27°C. (CO4-L1-MAY2011)

Solution:

$$1013 \text{ millibar} = 760 \text{ mm}$$

$$750 \text{ mm} = 1013/760 * 750 = 1000 \text{ millibar}$$

Correction factor = $(0,296*1000|273+37) = 0.955$

13.Explain the merits and demerits of analog and digital techniques used for high voltage measurements. (CO4-L1-MAY2011)

Information storage is easy that is accomplished by special switching circuit that latches on information and holds it for as long as necessary. Accuracy and precision are greater. Digital system can handle as many digits of precision as you need simply by adding more switching circuits.

14.What are the general methods used for measurement high frequency and impulse currents? (CO4-L1-MAY2011)

The following methods are used

- a) Resistive shunts
- b) Magnetic potentiometer or Rogowski coils
- c) Magnetic links
- d) Hall Effect generator.

PART B**1.Explain the various methods involved in DC measurement with neat diagrams(CO4-L1-MAY2011)****High Ohmic Series Resistance with Micro ammeter**

- ✓ High d.c. voltages are usually measured by connecting a very high resistance (few hundreds of mega ohms) in series with a micro ammeter as shown in Fig. Only the current I flowing through the large calibrated resistance R is measured by the moving coil micro ammeter. The voltage of the source is given by the voltage drop in the meter is negligible, as the impedance of the meter is only few ohms compared to few hundred mega-ohms of the series resistance R .
- ✓ A protective device like a paper gap, a neon glow tube, or a zener diode with a suitable series resistance is connected across the meter as a protection against high voltages in case the series resistance R fails or flashes over.
- ✓ The ohmic value of the series resistance R is chosen such that a current of one to ten microamperes is allowed for full-scale deflection. The resistance is constructed from a large number of wire wound resistors in series. The voltage drop in each resistor element is chosen to avoid surface flashovers and discharges. kV/cm in good oil is permissible.
- ✓ The resistor chain is provided with corona free terminations. The material for resistive elements is usually a carbon-alloy with temperature coefficient less than $10^{-4}/^{\circ}C$. Carbon and other metallic film resistors are also used.
- ✓ A resistance chain built with $\pm 1\%$ carbon resistors located in an airtight transformer oil filled P.V.C. tube, for 100 kV operations had very good temperature stability. The limitations in the series resistance design are:

- (i) power dissipation and source loading,
- (ii) temperature effects and longtime stability,
- (iii) voltage dependence of resistive elements, and
- (iv) sensitivity to mechanical stresses.

Series resistance meters are built for 500 kV d.c. with an accuracy better than 0.2%.

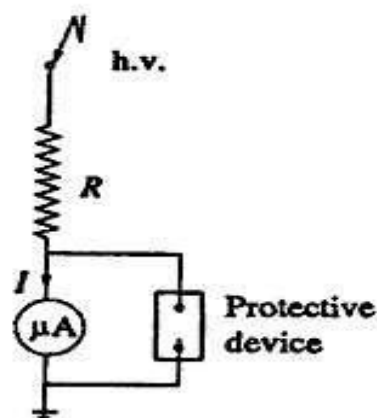

Resistance Potential Dividers for D.C. Voltages

- ✓ A resistance potential divider with an electrostatic or high impedance voltmeter is shown in Fig. The influence of temperature and voltage on the elements is eliminated in the voltage divider arrangement. The high voltage magnitude is given by $[(R_1 + R_2)/R_2]V_2$, where V_2 is the d.c. voltage across the low voltage arm R_2 .
- ✓ With sudden changes in voltage, such as switching operations, flashover of the test objects, or source short circuits, flashover or damage may occur to the divider elements due to the stray capacitance across the elements and due to ground capacitances.
- ✓ To avoid these transient voltages, voltage controlling capacitors are connected across the elements. A corona free termination is also necessary to avoid unnecessary discharges at high voltage ends.
- ✓ A series resistor with a parallel capacitor connection for linearization of transient potential distribution is shown in Fig. Potential dividers are made with 0.05% accuracy up to 100 kV, with 0.1% accuracy up to 300 kV, and with better than 0.5% accuracy for 500 kV.

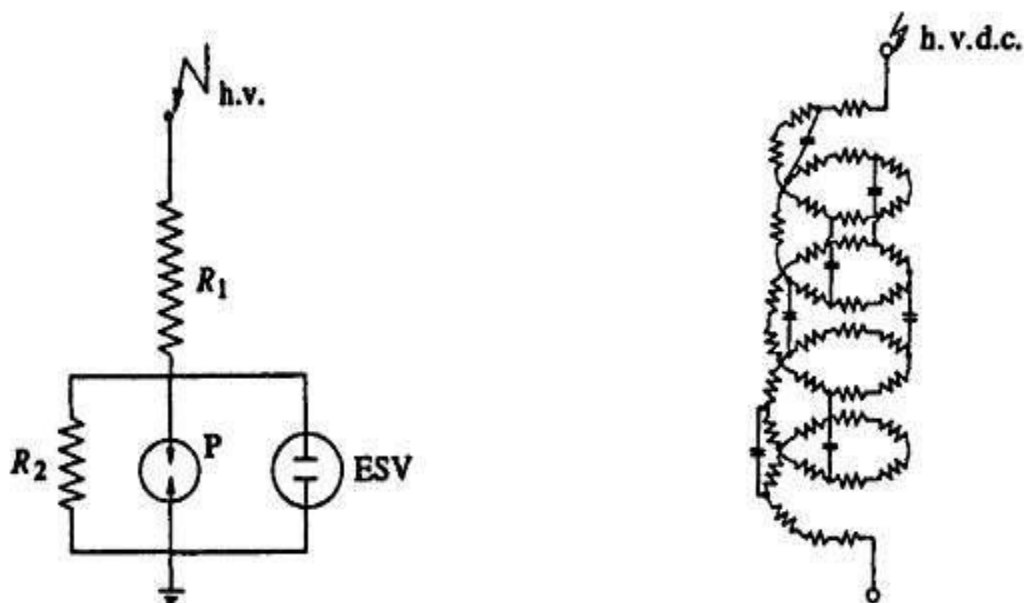

2. Explain with neat diagram Generating voltmeter.

Generating Voltmeters

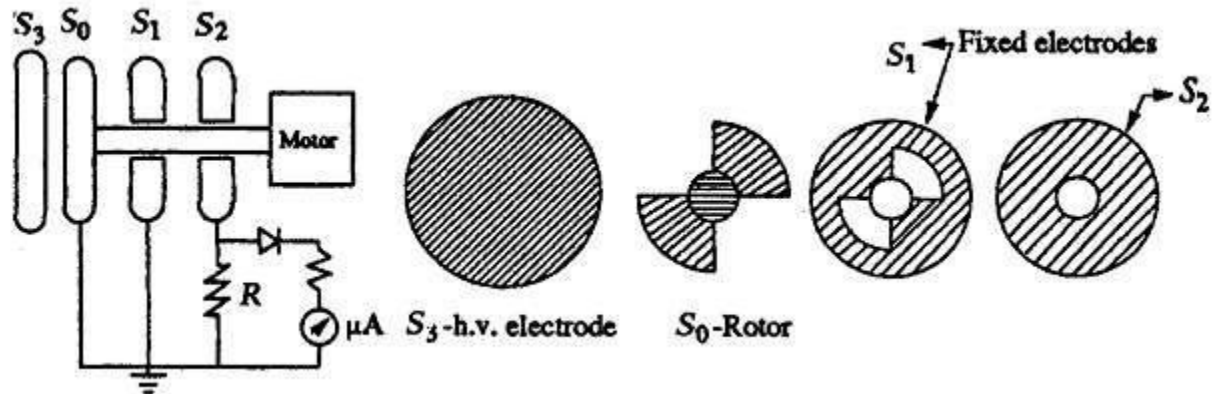

- ✓ High voltage measuring devices employ generating principle when source loading is prohibited (as with Van de Graff generators, etc.) or when direct connection to the high voltage source is to be avoided.
- ✓ A generating voltmeter is a variable capacitor electrostatic voltage generator which generates current proportional to the applied external voltage. The device is driven by an external synchronous or constant speed motor and does not absorb power or energy from the voltage measuring source
- ✓ A generating voltmeter with a rotating cylinder consists of two exciting field electrodes and a rotating two pole armature driven by a synchronous motor at a constant speed n . The a.c. current flowing between the two halves of the armature is rectified by a commutator.
- ✓ This device can be used for measuring a.c. voltages provided the speed of the drive-motor is half the frequency of the voltage to be measured. Thus a four-pole synchronous motor with 1500 rpm is suitable for 50 Hz.
- ✓ For peak value measurements, the phase angle of the motor must also be so adjusted that C_{max} and the crest value occur at the same instant. Generating voltmeters employ rotating sectors or vanes for variation of capacitance.
- ✓ Figure gives a schematic diagram of a generating voltmeter. The high voltage source is connected to a disc electrode S_3 which is kept at a fixed distance on the axis of the other low voltage electrodes S_0 , S_1 and S_2 . The rotor S_0 driven at a constant speed by a synchronous motor at a suitable speed (1500, 1800, 3000, or 3600 rpm).

- ✓ The rotor vanes of S_0 cause periodic change in capacitance between the insulated disc S_2 and the h.v. electrode S_3 . The shape and number of the vanes of S_0 and S_1 are so designed that they produce sinusoidal variation in the capacitance.
- ✓ The generated a.c. current through the resistance R is rectified and read by a moving coil instrument an amplifier is needed, if the shunt capacitance is large or longer leads are used for connection to rectifier and meter. The instrument is calibrated using a potential divider or sphere gap. The meter scale is linear and its range can be extended

Advantages of Generating Voltmeters

- (i) No source loading by the meter,
- (ii) no direct connection to high voltage electrode,
- (iii) scale is linear and extension of range is easy, and
- (iv) A very convenient instrument for electrostatic devices such as Van de Graff generator and particle accelerators.

Limitations of Generating Voltmeters

- (i) They require calibration,
- (ii) careful construction is needed and is a cumbersome instrument requiring an auxiliary drive,
- (iii) Disturbance in position and mounting of the electrodes make the calibration invalid.

3. Explain the various methods involved in High AC measurement with neat diagrams(CO4-L1-MAY2011)

Series Impedance Voltmeters

- ✓ For power frequency a.c. measurements the series impedance may be a pure resistance or a reactance. Since resistances involve power losses, often a capacitor is preferred as a series reactance.
- ✓ Moreover, for high resistances, the variation of resistance with temperature is a problem, and the residual inductance of the resistance gives rise to an impedance different from its ohmic resistance.
- ✓ High resistance units for high voltages have stray capacitances and hence a unit resistance will have an equivalent circuit as shown in Fig. At any frequency ω of the a.c. voltage, the impedance of the resistance R is For power frequency a.c. measurements the series impedance may be a pure resistance or a reactance.

- ✓ Since resistances involve power losses, often a capacitor is preferred as a series reactance. Moreover, for high resistances, the variation of resistance with temperature is a problem, and the residual inductance of the resistance gives rise to impedance different from its ohmic resistance.
- ✓ High resistance units for high voltages have stray capacitances and hence a unit resistance will have an equivalent circuit as shown in Fig. At any frequency ω of the a.c. voltage, the impedance of the resistance R is

$$Z = \frac{R + j\omega L}{(1 - \omega^2 LC) + j\omega CR}$$

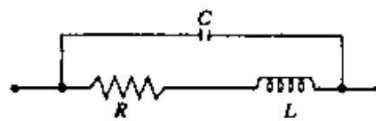

Simplified lumped parameter equivalent circuit of a high ohmic resistance R

L — Residual inductance

C — Residual capacitance

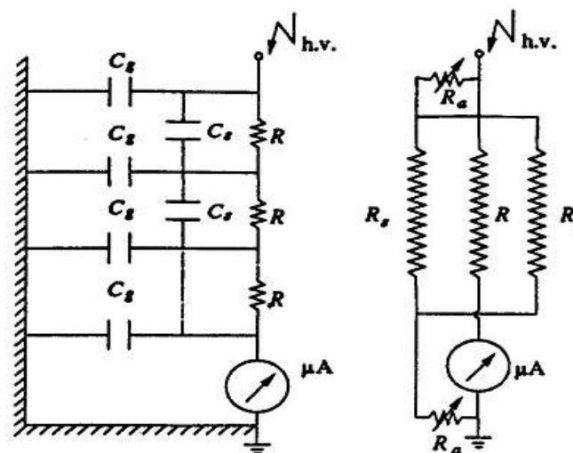

- ✓ For extended and large dimensioned resistors, this equivalent circuit is not valid and each elemental resistor has to be approximated with this equivalent circuit.
- ✓ The entire resistor unit then has to be taken as a transmission line equivalent, for calculating the effective resistance. Also, the ground or stray capacitance of each element influences the current flowing in the unit, and the indication of the meter results in an error.

- ✓ The equivalent circuit of a high voltage resistor neglecting inductance and the circuit of compensated series resistor using guard and timing resistors is shown in fig respectively.
- ✓ Stray ground capacitance effects can be removed by shielding the resistor by a second surrounding spiral R_s , which shunts the actual resistor but does not contribute to the current through the instrument.
- ✓ By tuning the resistors R_a the shielding resistor end potentials may be adjusted with respect to the actual measuring resistor so that the resulting compensation currents between the shield and the measuring resistors provide a minimum phase angle.

Series Capacitance Voltmeter

To avoid the drawbacks pointed out earlier, a series capacitor is used instead of a resistor for a.c. high voltage measurements. The schematic diagram is shown in Fig.. The current I_c through the meter is:

$$I_c = j \omega C V$$

Hence, the resultant rms current is:

$$I = \omega C (V_1^2 + 4V_2^2 + \dots + n^2V_n^2)^{1/2}$$

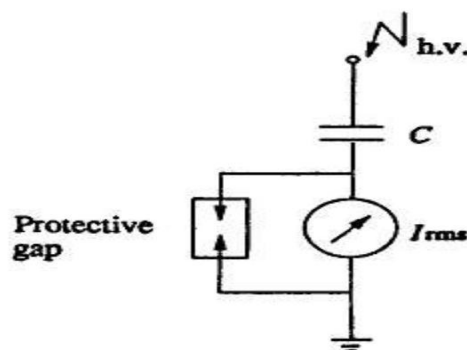

- ✓ Series capacitance voltmeters were used with cascade transformers for measuring rms values up to 1000 kV. The series capacitance was formed as a parallel plate capacitor between the high voltage terminal of the transformer and a ground plate suspended above it.
- ✓ A rectifier ammeter was used as an indicating instrument and was directly calibrated in high voltage RMS value. The meter was usually a 0-100 μ A moving coil meter and the overall error was about 2%.

4. Explain the working of CVT with diagrams. (CO4-L1-MAY2011)

CAPACITANCE VOLTAGE TRANSFORMER—CVT

- ✓ Capacitance divider with a suitable matching or isolating potential transformer tuned for resonance condition is often used in power systems for voltage measurements. This is often referred to as CVT.
- ✓ In contrast to simple capacitance divider which requires a high impedance meter like or an electrostatic condenser voltmeter, a CVT can be connected to a low impedance device like a condenser wattmeter pressure coil or a relay coil CVT can supply load of a few VA.
- ✓ The schematic diagram of a CVT with its equivalent circuit is given in Fig. C1 is made of a few units of high voltage condensers, and the total capacitance will be around a few thousand picofarads as against a gas filled standard condenser of about 100 pF.
- ✓ A matching transformer is connected between the load or meter M and C2. The transformer ratio is chosen on economic grounds, and the h.v. winding rating may be 10 to 30 kV with the Lv. winding rated from 100 to 500 V.
- ✓ The value of the tuning choke L is chosen to make the equivalent circuit of the CVT purely resistive or to bring resonance condition. This condition is satisfied when

$$\omega(L + L_T) = \frac{1}{\omega(C_1 + C_2)}$$

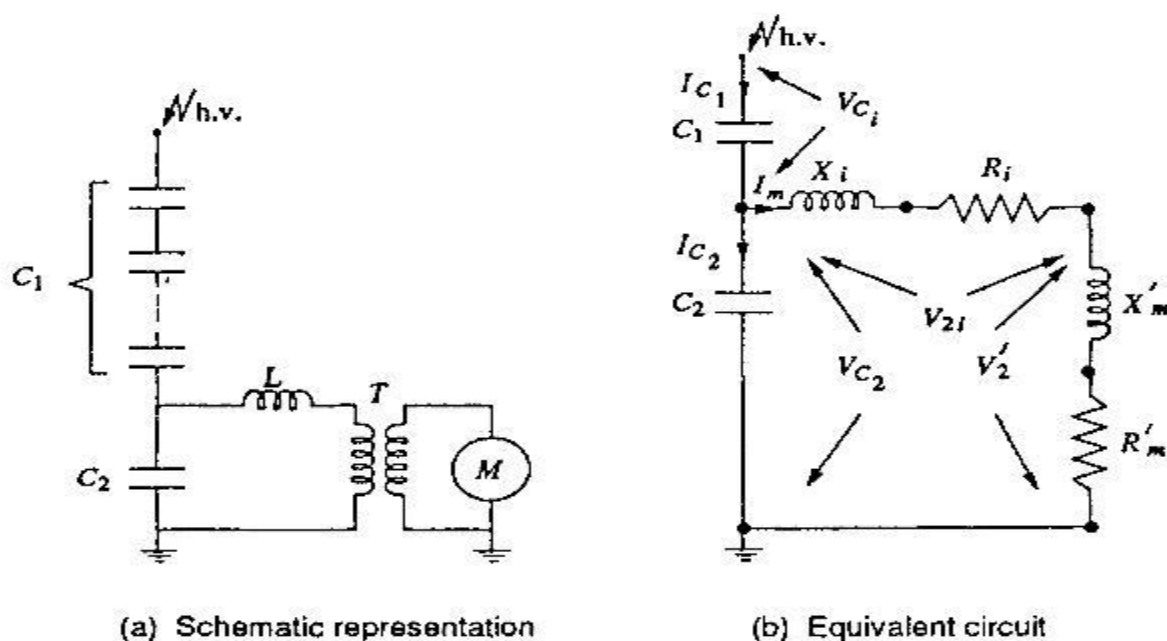

The advantages of a CVT are:

- (i) simple design and easy installation,
- (ii) Can be used both as a voltage measuring device for meter and relaying purposes and also as a coupling condenser for power line carrier communication and relaying.
- (iii) frequency independent voltage distribution along elements as against conventional magnetic potential transformers which require additional insulation design against surges, and
- (iv) Provides isolation between the high voltage terminal and low voltage metering.

The disadvantages of a CVT are:

- (i) the voltage ratio is susceptible to temperature variations, and
- (ii) The problem of inducing Ferro-resonance in power systems.

5.Explain the working of Electrostatic Voltmeters with diagrams. (CO4-L1-MAY2011)**Electrostatic Voltmeters****Construction**

Electrostatic voltmeters are made with parallel plate configuration using guard rings to avoid corona and field fringing at the edges. An absolute voltmeter is made by balancing the plate with a counter weight and is calibrated in terms of a small weight.

Usually the electrostatic voltmeters have a small capacitance (5 to 50 pF) and high insulation resistance ($R > 10^{13} \Omega$). Hence they are considered as devices with high input impedance. The upper frequency limit for a.c. applications is determined from the following considerations:

- (i) natural frequency of the moving system,
- (ii) resonant frequency of the lead and stray inductances with meter capacitance,
- (iii) The R-C behavior of the retaining or control spring
 - ✓ An upper frequency limit of about one MHz is achieved in careful designs. The accuracy for a.c. voltage measurements is better than $\pm 0.25\%$, and for d.c. voltage measurements it may be $\pm 0.1\%$ or less.
 - ✓ The schematic diagram of an absolute electrostatic voltmeter or electrometer is given in Fig. It consists of parallel plane disc type electrodes separated by a small distance. The moving electrode is surrounded by a fixed guard ring to make the field uniform in the central region.
 - ✓ In order to measure the given voltage with precision, the disc diameter is to be increased, and the gap distance is to be made less. The limitation on the gap distance is the safe working stress (V/s) allowed in air which is normally 5 kV/cm or less.

- ✓ The main difference between several forms of voltmeters lies in the manner in which the restoring force is obtained. For conventional versions of meters, a simple spring control is used, which actuates a pointer to move on the scale of the instruments.
- ✓ In more versatile instruments, only small movements of the moving electrodes are allowed, and the movement is amplified through optical means (lamp and scale arrangement as used with moving coil galvanometers).
- ✓ Two air vane dampers are used to reduce vibrational tendencies in the moving system, and the elongation of the spring is kept minimum to avoid field disturbances. The range of the instrument is easily changed by changing the gap separation so that V/s or electric stress is the same for the maximum value in any range.
- ✓ Multi-range instruments are constructed for 600 W rms and above. The constructional details of an absolute electrostatic voltmeter are given in Fig. The control torque is provided by a balancing weight the moving disc M forms the central core of the guard ring G which is of the same diameter as the fixed plate F.
- ✓ The cap D encloses a sensitive balance B, one arm of which carries the suspension of the moving disc. The balance beam carries a mirror which reflects a beam of light. The movement of the disc is thereby magnified.
- ✓ As the spacing between the two electrodes is large, the uniformity of the electric field is maintained by the guard rings H which surround the space between the discs F and M. The guard rings H are maintained at a constant potential in space by a capacitance divider ensuring a uniform special potential distribution.
- ✓ Some instruments are constructed in an enclosed structure containing compressed air, carbon dioxide, or nitrogen. The gas pressure may be of the order of 15 atm. working stresses as high as 100 kV/cm may be used in an electrostatic meter in Light sources vacuum. With compressed gas or vacuum as medium, the meter is compact and much smaller in size.

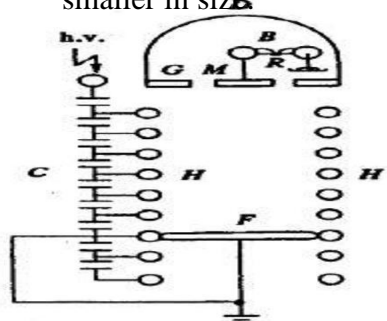

(a) Absolute electrostatic voltmeter

M — Mounting plate
G — Guard plate
F — Fixed plate
H — Guard hoops or rings

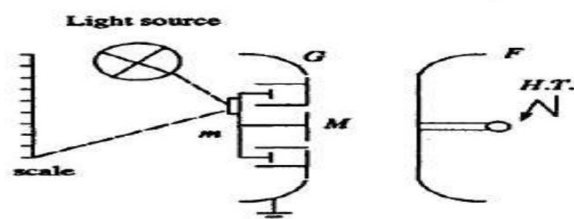

(b) Light beam arrangement

m — mirror
B — Balance
C — Capacitance divider
D — Dome
R — Balancing weight

6.Explain the working of Spark Gaps for Measurement of High D.C., A.C. and Impulse Voltages(CO4-L1-MAY2011)

Spark Gaps for Measurement of High D.C., A.C. and Impulse Voltages (Peak Values)

- ✓ A uniform field spark gap will always have a spark over voltage within a known tolerance under constant atmospheric conditions. Hence a spark gap can be used for measurement of the peak value of the voltage, if the gap distance is known.
- ✓ A spark over voltage of 30 kV (peak) at 1 cm spacing in air at 20⁰ C and 760 torr pressure occurs for a sphere gap or any uniform field gap. But experience has shown that these measurements are reliable only for certain gap configurations.
- ✓ Normally, only sphere gaps are used for voltage measurements. In certain cases uniform field gaps and rod gaps are also used, but their accuracy is less. The spark gap breakdown, especially the sphere gap breakdown, is independent of the voltage waveform and hence is highly suitable for all types of waveforms from d.c. to impulse voltages of short rise times (rise time > 0.5 M. s).
- ✓ As such, sphere gaps can be used for radio frequency a.c. voltage peak measurements also (up to 1 MHz). Sphere Gap Measurements Sphere gaps can be arranged either (i) vertically with lower sphere grounded, or (ii) horizontally with both spheres connected to the source voltage or one sphere grounded.
- ✓ In horizontal configurations, it is generally arranged such that both spheres are symmetrically at high voltage above the ground. The two spheres used are identical in size and shape. The schematic arrangement is shown in Figs..
- ✓ The voltage to be measured is applied between the two spheres and the distance or spacing s between them gives a measure of the spark over voltage. A series resistance is usually connected between the source and the sphere gap to (i) limit the breakdown current, and (ii) to suppress unwanted oscillations in the source voltage when breakdown occurs (in case of impulse voltages).
- ✓ The value of the series resistance may vary from 100 to 1000 kilo ohms for a.c. or d.c. voltages and not more. In the case of a.c. peak value and d.c. voltage measurements, the applied voltage is uniformly increased until spark over occurs in the gap.
- ✓ Generally, a mean of about five breakdown values is taken when they agree to within $\pm 3\%$. In the case of impulse voltages, to obtain 50% flashover voltage, two voltage limits, differing by not more than 2% are set such that on application of lower limit value either 2 or 4 flashovers take place or on application of upper limit value 8 or 6 flashovers take place respectively.
- ✓ The mean of these two limits is taken as 50% flashover voltage. In any case, a preliminary spark over voltage measurement is to be made before actual measurements are made.

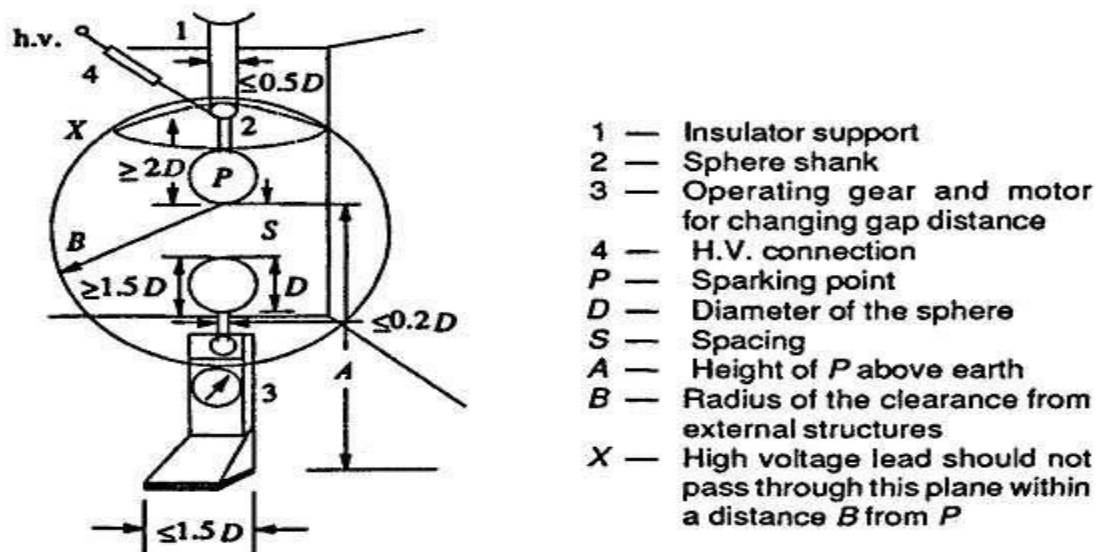

(a) Vertical arrangement of sphere gap

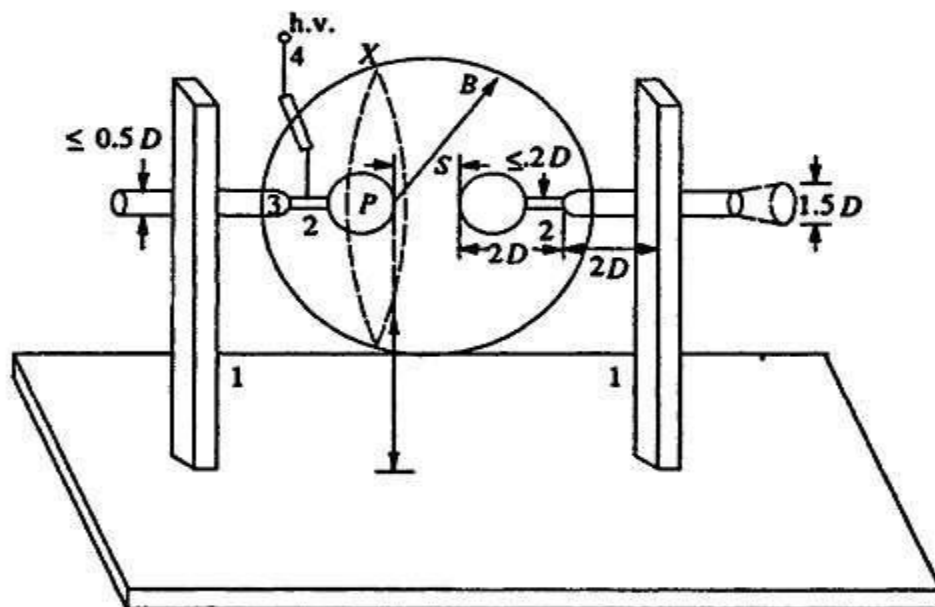

Factors Influencing the Sparkover Voltage of Sphere Gaps

Various factors that affect the sparkover voltage of a sphere gap are:

- (i) nearby earthed objects,
- (ii) atmospheric conditions and humidity,
- (iii) irradiation, and
- (iv) Polarity and rise time of voltage waveforms.

Effect of nearby earthed objects

The effect of nearby earthed objects was investigated by enclosing the earthed sphere inside an earthed cylinder. It was observed that the spark overvoltage is reduced. The reduction was observed to be

$$\Delta V = m \log (B/D) + C$$

ΔV = percentage reduction,

B = diameter of earthed enclosing cylinder,

D = diameter of the spheres,

S = spacing, and m and C are constants.

(ii) Effect of atmospheric conditions

The sparkover voltage of a spark gap depends on the air density which varies with the changes in both temperature and pressure. If the sparkover voltage is V under test conditions of temperature T and pressure p torr and if the sparkover voltage is V_0 under standard conditions of temperature $T = 20^\circ\text{C}$ and pressure $p = 760$ torr, then

$$V = kV_0$$

where k is a function of the air density factor d , given by

$$d = \frac{p}{760} \left(\frac{293}{273+T} \right)$$

(iii) Effect of Irradiation

Illumination of sphere gaps with ultra-violet or x-rays aids easy ionization in gaps. The effect of irradiation is pronounced for small gap spacings. A reduction of about 20% in sparkover voltage was observed for spacings of $0.1 D$ to $0.3 D$ for a 1.3 cm sphere gap with d.c. voltages. The reduction in sparkover voltage is less than 5% for gap spacings more than 1 cm, and for gap spacings of 2 cm or more it is about 1.5%. Hence, irradiation is necessary for smaller sphere gaps of gap spacing less than 1 cm for obtaining consistent values.

(iv) Effect of polarity and waveform

It has been observed that the sparkover voltages for positive and negative polarity impulses are different. Experimental investigation showed that for sphere gaps of 6.25 to 25 cm diameter, the difference between positive and negative d.c. voltages is not more than 1%. For smaller sphere gaps (2 cm diameter and less) the difference was about 8% between negative and positive impulses of $1/50 \mu\text{s}$ waveform. Similarly, the wave front and wave tail durations also influence the breakdown voltage. For wave fronts of less than $0.5 \mu\text{s}$ and wave tails less than $5 \mu\text{s}$ the breakdown voltages are not consistent and hence the use of sphere gap is not recommended for voltage measurement in such cases.

7. Explain the working of measurement of high d.c., a.c. and impulse currents (CO4-L1-MAY2011)**MEASUREMENT OF HIGH D.C., A.C. AND IMPULSE CURRENTS**

In power systems, it is often necessary to measure high currents, arising due to short circuits. For conducting temperature rise and heat run tests on power equipment's like conductors, cables, circuit breakers, etc., measurement of high currents is required. During lightning discharges and switching transients also, large magnitudes of impulse and switching surge currents occur, which require special measuring techniques at high potential levels.

Measurement of High Direct Currents

High magnitude direct currents are measured using a resistive shunt of low ohmic value. The voltage drop across the resistance is measured with a milli voltmeter. The value of the resistance varies usually between $10 \mu\Omega$ and $13 \text{ m}\Omega$. This depends on the heating effect and the loading permitted in the circuit. High current resistors are usually oil immersed and are made as three or four terminal resistances. The voltage drop across the shunt is limited to a few millivolts ($< 1 \text{ Volt}$) in power circuits.

Hall Generators for d.c. Current Measurements

- ✓ The principle of the "Hall effect" is made use of in measuring very high direct currents. If electric current flows through a metal plate located in a magnetic field perpendicular to it, Lorentz forces will deflect the electrons in the metal structure in a direction normal to the direction of both the current and the magnetic field. The charge displacement generates an emf in the normal direction, called the 'Hall voltage'.
- ✓ The Hall voltage is proportional to the current i , the magnetic flux density B , and the reciprocal of the plate thickness d ; the proportionality constant R is called the "Hall coefficient". or metals the Hall coefficient is very small, and hence semi-conductor materials are used for which the Hall coefficient is high.
- ✓ In large current measurements, the current carrying conductor is surrounded by an iron cored magnetic circuit, so that the magnetic field intensity $H = (1/\delta)$ is produced in a small air gap in the core.
- ✓ The Hall element is placed in the air gap (of thickness), and a small constant d.c. current is passed through the element. The schematic arrangement is shown in Fig. The voltage developed across the Hall element in the normal direction is proportional to the d.c. current I .
- ✓ It may be noted that the Hall coefficient R depends on the temperature and the high magnetic field strengths, and suitable compensation has to be provided when used for measurement of very high currents.

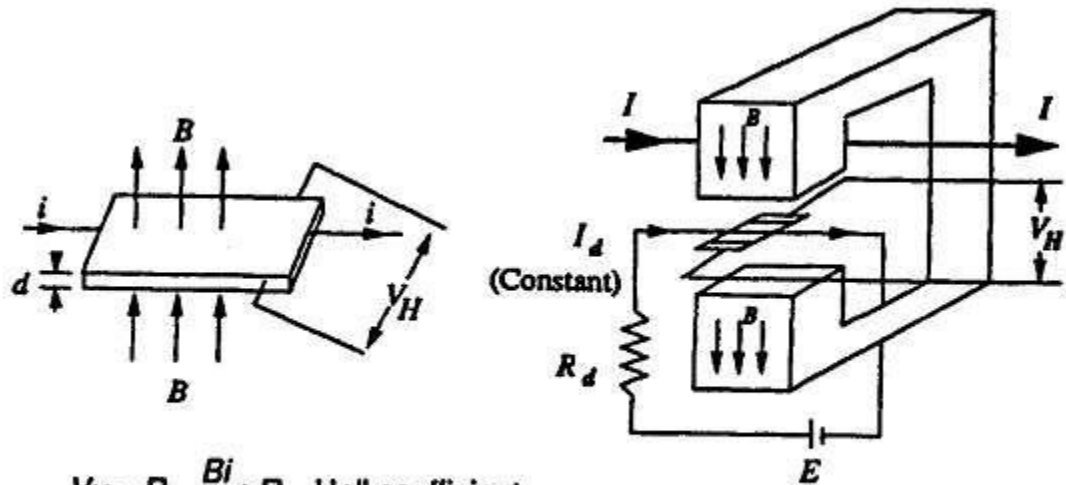

$$V_H = R \cdot \frac{Bi}{d}; R = \text{Hall coefficient}$$

(a) Hall effect

(b) Hall generator

Measurement of High Power Frequency

Alternating Currents Measurement of power frequency currents are normally done using current transformers only, as use of current shunts involves unnecessary power loss. Also the current transformers provide electrical isolation from high voltage circuits in power systems.

Current transformers used few extra high voltage (EHV) systems are quite different from the conventional designs as they have to be kept at very high voltages from the ground. A new scheme of current transformer measurements introducing electro-optical technique is described in Fig voltage signal proportional to the measuring current is generated and is transmitted to the ground side through an electro-optical device.

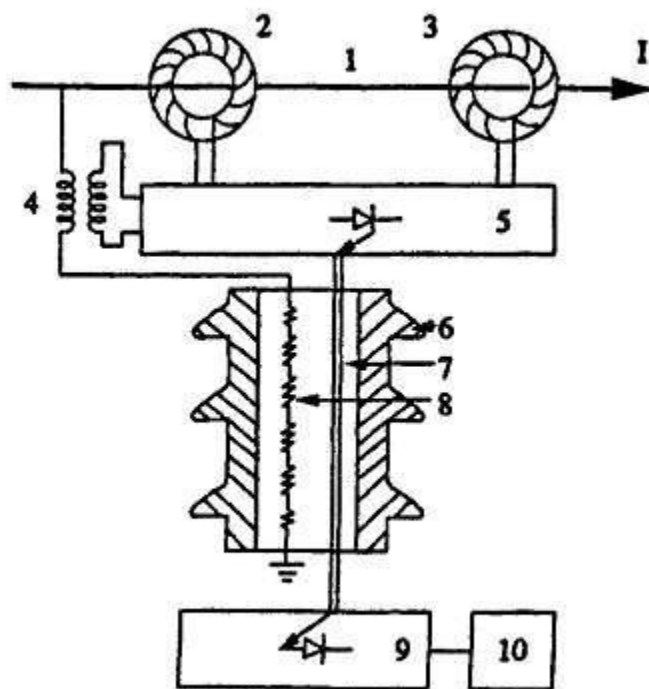

1. EHV conductor
2. Current sensing transformer
3. Power supply C.T.
4. Power supply P.T.
5. Analog-digital signal converter
6. Insulator for EHV
7. Electro-optical glass fibre
8. Series high ohmic resistance
9. Digital-analog converter
10. Indicating or recording unit

Light pulses proportional to the voltage signal are transmitted by a glass-optical fibre bundle to a photo detector and converted back into an analog voltage signal. Accuracies better than $\pm 0.5\%$ have been obtained at rated current as well as for high short circuit currents. The required power for the signal converter and optical device are obtained from suitable current and voltage transformers as shown in the Fig.

MEASUREMENT OF HIGH IMPULSE CURRENTS USING MAGNETIC POTENTIOMETERS

(Rogowski Colls) and Magnetic Links:

If a coil is placed surrounding a current carrying conductor, the voltage signal induced in the coil $V_i(t) = M \frac{dI(t)}{dt}$ where M is the mutual inductance between the conductor and the coil, and $I(t)$ is the current flowing in the conductor.

Usually, the coil is wound on a nonmagnetic former of toroidal shape and is coaxially placed surrounding the current carrying conductor. The number of turns on the coil is chosen to be large, to get enough signal induced.

The coil is wound cross-wise to reduce the leakage inductance. Usually an integrating circuit is employed to get the output signal voltage proportional to the current to be measured. The output voltage is given by

$$V_m(t) = \frac{1}{CR} \int_0^t v_i(t) dt = \frac{M}{CR} I(t)$$

Rogowski coils with electronic or active integrator circuits have large bandwidths (about 100 MHz). At frequencies greater than 100 MHz the response is affected by the skin effect, the capacitance distributed per unit length along the coil, and due to the electromagnetic interferences.

However, miniature probes having nanosecond response time are made using very few turns of copper strips for UHF measurements.

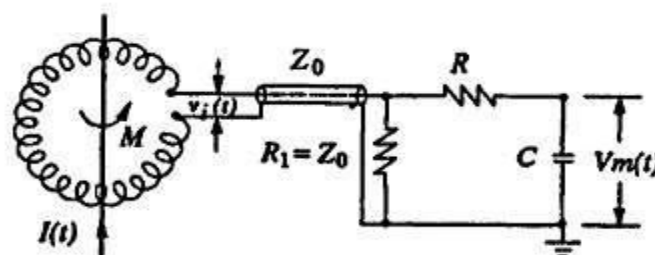

- $V_i(t)$ — Induced voltage in the coil = $M \frac{d[I(t)]}{dt}$
 Z_0 — Coaxial cable of surge impedance Z_0
 R-C — Integrating network

CATHODE RAY OSCILLOGRAPHS FOR IMPULSE VOLTAGE AND CURRENT MEASUREMENTS

- ✓ When waveforms of rapidly varying signals (voltages or currents) have to be measured or recorded, certain difficulties arise. The peak values of the signals in high voltage measurements are too large, may be several kilovolts or kiloamperes. Therefore, direct measurement is not possible. The magnitudes of these signals are scaled down by voltage dividers or shunts to smaller voltage signals.
- ✓ The reduced signal $V_m(f)$ is normally proportional to the measured quantity. The procedure of transmitting the signal and displaying or recording it is very important. The associated electromagnetic fields with rapidly changing signals induce disturbing voltages, which have to be avoided.
- ✓ The cathode ray oscilloscope for impulse work normally has input voltage range from 5 mV/cm to about 20 V/cm. In addition, there are probes and attenuators to handle signals up to 600 V (peak to peak). The bandwidth and rise time of the oscilloscope should be adequate.
- ✓ Rise times of 5 ns and bandwidth as high as 500 MHz may be necessary. Sometimes high voltage surge test oscilloscopes do not have vertical amplifier and directly require an input voltage of 10 V. They can take a maximum signal of about 100 V (peak to peak) but require suitable attenuators for large signals.
- ✓ Oscilloscopes are fitted with good cameras for recording purposes. Tektronix model 7094 is fitted with a lens of 1: 1.2 polaroid camera which uses 10,000 ASA film which possesses a writing speed of 9 cm/ns.
- ✓ With rapidly changing signals, it is necessary to initiate or start the oscilloscope time base before the signal reaches the oscilloscope deflecting plates, otherwise a portion of the signal may be missed. Such measurement requires an accurate initiation of the horizontal time base and is known as triggering. Oscilloscopes are normally provided with both internal and external triggering facilities.

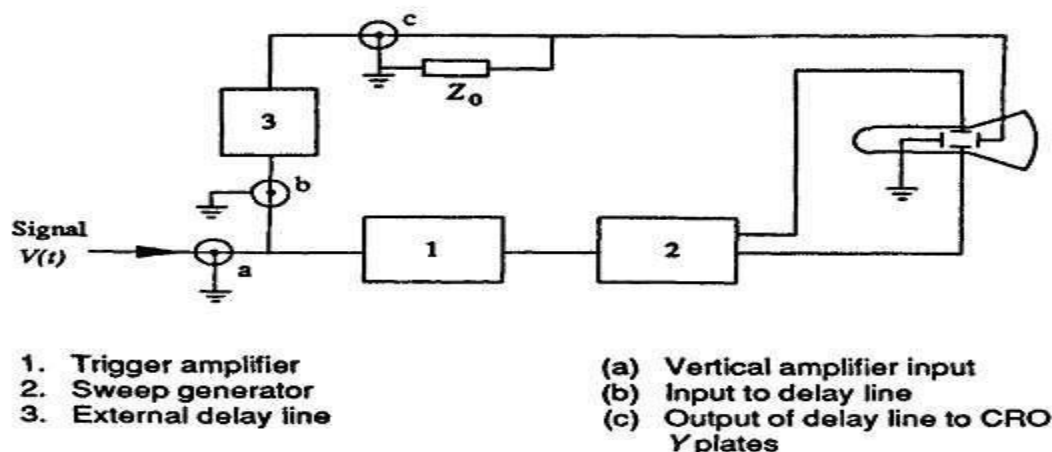

UNIT 5**HIGH VOLTAGE TESTING AND INSULATION COORDINATION****PART A****1. What are tests conducted on insulators? (CO5-L1-MAY2013)**

- i) Power frequency voltage test
- ii) Impulse voltage test
 - a) Dry and wet flashover tests
 - b) Wet and dry withstand tests (one minute)

Impulse tests can be classified into

- a) Impulse withstand voltage test
- b) Impulse flashover test
- c) Pollution testing.

2. What are test conducted on Bushings? (CO5-L1-MAY2013)

- i) Power frequency voltage test
- ii) Impulse voltage test
 - a) Power factor voltage test
 - b) Internal or partial discharge test
 - c) Momentary withstand test at power frequency
 - d) One minute wet withstand test at power frequency test
 - e) Visible discharge test at power frequency

impulse voltage tests can be classified into

- a) Full wave withstand test
- b) Chopped wave withstand and switching surge test

C] Temperature rise and thermal stability tests are also used for testing of bushings.

3. Define withstand voltage. (CO5-L1-MAY2013)

The voltage which has to be applied to attest object under specified condition in a withstand test is called the withstand voltage.

4. Define impulse voltage. (CO5-L1-MAY2013)

Impulse voltage is characterized by polarity. Peak value, time to front and time to half the peak value after the peak. The time to front is defined as 1.67 times to time between 30 % and 90 % of the peak value in the rising portion of the wave. According to [s : 207] (1973) standard impulse is defined as one with $t_f = 1.2 \mu\text{s}$, $t_t = 50 \mu\text{s}$ (called 1.250 μs wave). The tolerances allowed are $\pm 3\%$ on the peak value, $\pm 30\%$ in the front time (t_f), and $\pm 20\%$ in the tail time (t_t).

5. Differentiate type test and routine test. (CO5-L1-MAY2013)

Routine test is not to flash over the insulator but rather to detect existing fault before the insulator is put in service. Type test cover those features that are important to the purchaser such as dry and wet flash over, puncture voltage, tensile strength.

6. Define Disruptive discharge voltage. (CO5-L1-MAY2013)

This is defined as the voltage which produces the loss of dielectric strength of an insulation. It is that voltage at which the electrical stress in the insulation causes a failure which includes the collapses of voltage and passage of current.

7. What are the atmosphere correction factor and mention their influence in high voltage testing. (CO5-L1-MAY2013)

Actual air density during measurement differs due to temperature and pressure variation.

Spark over voltage depends upon the air density

factor Spark over voltage $V = KV_0$

Where ,K = Correction factor related to air density factor 'd'

V_0 = Spark over voltage under standard temperature and pressure.

$d = P/P_0[(273 + t_0) / (273 +$

T)] Where

K is a function of air density factor

d P = air pressure at test condition

P_0 = air pressure at standard condition

t_0 = temperature at standard condition

T = temperature at test condition

8.Explain the role of Bureau of Indian standards in high voltage testing. (CO5-L1-MAY2013)

All the EHV equipment voltage are governed by Indian standard specification issued by Bureau of Indian standards in our country.

For different transmission voltages the test voltages are given in a tubular form.

9.Define insulation co- ordination. (CO5-L1-MAY2013)

Insulation co-ordination of suitable values for the insulation levels of the various components in any electrical system and their management in a rational manner is called insulation co-ordination Insulation co-ordination of the insulation of the electrical equipment and circuits with the characteristics of the protective devices in such a manner that the insulation is well protected from the excessive over voltages.

10.What is the significance of impulse tests? (CO5-L1-MAY2013)

Impulse test are done on insulator to ensure reliability of individual test objects and quality and consistency of material used in their manufacture and done on transformers is to determine the ability of the insulation of transformers to withstand the transient voltages due to lightning.

11.Name the different types of tests conducted on high voltage apparatus. (CO5-L1-MAY2013)

Dry -Wet flashover test and Dry -Wet withstands test are the two types of tests conducted on high voltage apparatus.

12.Explain the reasons for conducting wet tests on high voltage apparatus and give the specifications of the water used for wet tests. (CO5-L1-MAY2013)

Wet tests are to provide a criterion based on experience that a satisfactory service operation will be obtained.

Conductivity of water 100 microsiemens \pm 10 % Water
temperature ambient \pm 15 %

13. Define creepage distance. (CO5-L1-MAY2013)

It is the shortest distance of contour of the external surface of the insulator unit or between two metal fittings on the insulator.

14. Give the Indian standard reference atmospheric conditions for high voltage testing. (CO5-L1-MAY2013)

- a) Temperature - 27°C
- b) Pressure - 1013 millibars (or 70 torr)
- c) Absolute humidity – 17 gm/m³

15. Define safety margin as applied to be insulation co-ordination. (CO5-L1-MAY2013)

Safety margin applied to insulation co-ordination is the basic insulation level of equipment is defined as the peak voltage of 1.2 / 50 μ s wave which does not cause insulation to fail. The definition of a surge (1.2 / 50 μ s) indicates a surge which reaches its peak value in 1.2 μ s and decays to half the peak in 50 μ s.

PART B

1. Mention the different Electrical test on Over Head insulators (CO5-L1-MAY2013)

TESTING OF OVERHEAD LINE INSULATORS

Various types of overhead line insulators are

- (i) Pin type
- (ii) Post type
- (iii) String insulator unit
- (iv) Suspension insulator string
- (v) Tension insulator.

Arrangement of Insulators for Test

String insulator unit should be hung by a suspension eye from an earthed metal cross arm. The test voltage is applied between the cross arm and the conductor hung vertically down from the metal part on the lower side of the insulator unit. Suspension string with all its accessories as in service should be hung from an earthed metal cross arm. The length of the cross arm should be at least 1.5 times the length of the string being tested and should be at least equal to 0.9 m on either side of the axis of the string. No other earthed object should be nearer to the insulator string than 0.9 m or 1.5 times the length of the string whichever is greater. A conductor of actual size to be used in service or of diameter not less than 1 cm and length 1.5 times the length of the string is secured in the suspension clamp and should lie in a horizontal plane. The test voltage is applied between the conductor and the cross arm and connection from the impulse generator is made with a length of wire to one end of the conductor. For higher operating voltages where the length of the string is large, it is advisable to sacrifice the length of the conductor as stipulated above. Instead, it is desirable to bend the ends of the conductor over in a large radius. For tension insulators the arrangement is more or less same as in suspension insulator except that it should be held in an approximately horizontal position under a suitable tension (about 1000 Kg.). For testing pin insulators or line post insulators, these should be mounted on the insulator pin or line post shank with which they are to be used in service. The pin or the shank should be fixed in a vertical position to a horizontal earthed metal cross arm situated 0.9 m above the floor of the laboratory. A conductor of 1 cm diameter is to be laid horizontally in the top groove of the insulator and secured by at least one turn of tie-wire, not less than 0.3 cm diameter in the tie-wire groove. The length of the wire should be at least 1.5 times the length of the insulator and should

over hang the insulator at least 0.9 mm either side in a direction at right angles to the cross arm.

The test voltage is applied to one end of the conductor.

High voltage testing of electrical equipment requires two types of tests:

- (i) Type tests, and
- (ii) Routine test.

Type tests involves quality testing of equipment at the design and development level i.e.samples of the product are taken and are tested when a new product is being developed and designed or an old product is to be redesigned and developed whereas the routine tests are meant to check the quality of the individual test piece. This is carried out to ensure quality and reliability of individual test objects.High voltage tests include

- (i) Power frequency tests and
- (ii) Impulse tests.

These tests are carried out on all insulators.

- (i) 50% dry impulse flash over test.
- (ii) Impulse withstand test.
- (iii) Dry flash over and dry one minute test.
- (iv) Wet flash over and one minute rain test.
- (v) Temperature cycle test.
- (vi) Electro-mechanical test.
- (vii) Mechanical test.
- (viii) Porosity test.
- (ix) Puncture test.
- (x) Mechanical routine test.

The tests mentioned above are briefly described here.

(i) The test is carried out on a clean insulator mounted as in a normal working condition. An impulse voltage of $1/50 \mu$ sec. wave shape and of an amplitude which can cause 50% flash over of the insulator, is applied, i.e. of the impulses applied 50% of the impulses should cause flash over. The polarity of the impulse is then reversed and procedure repeated. There must be at least 20 applications of the impulse in each case and the insulator must not be damaged. The magnitude of the impulse voltage should not be less than that specified in standard specifications.

(ii) The insulator is subjected to standard impulse of $1/50 \mu$ sec. wave of specified value under dry conditions with both positive and negative polarities. If five consecutive applications do not cause any flash over or puncture, the insulator is deemed to have passed the impulse withstand test. If out of five, two applications cause flash over, the insulator is deemed to have failed the test.

(iii) Power frequency voltage is applied to the insulator and the voltage increased to the specified value and maintained for one minute. The voltage is then increased gradually until flash over occurs. The insulator is then flashed over at least four more times, the voltage is raised gradually to reach flash over in about 10 seconds. The mean of at least five consecutive flash over voltages must not be less than the value specified in specifications.

(iv) If the test is carried out under artificial rain, it is called wet flash over test. The insulator is subjected to spray of water of following characteristics:

Precipitation rate	$3 \pm 10\%$ mm/min.
Direction	45° to the vertical
Conductivity of water	100 micro siemens $\pm 10\%$
Temperature of water	Ambient $+15^\circ\text{C}$

The insulator with 50% of the one-min. rain test voltage applied to it, is then sprayed for two minutes, the voltage raised to the one minute test voltage in approximately 10 sec. and maintained there for one minute. The voltage is then increased gradually till flash over occurs and the insulator is then lashed at least four more times, the time taken to reach flash over voltage being in each case about 10 sec. The flash over voltage must not be less than the value specified in specifications.

(v) The insulator is immersed in a hot water bath whose temperature is 70° higher than normal water bath for T minutes. It is then taken out and immediately immersed in normal water bath for T minutes. After T minutes the insulator is again immersed in hot water bath for T minutes. The cycle is repeated three times and it is expected that the insulator should withstand the test without damage to the insulator or glaze. Here $T = (15 + W/1.36)$ where W is the weight of the insulator in kgs.

(vi) The test is carried out only on suspension or tension type of insulator. The insulator is subjected to a $2\frac{1}{2}$ times the specified maximum working tension maintained for one minute. Also, simultaneously 75% of the dry flash over voltage is applied. The insulator should withstand this test without any damage.

(vii) This is a bending test applicable to pin type and line-post insulators. The insulator is subjected to a load three times the specified maximum breaking load for one minute. There should be no damage to the insulator and in case of post insulator the permanent set must be less than 1%. However, in case of post insulator, the load is then raised to three times and there should not be any damage to the insulator and its pin.

(viii) The insulator is broken and immersed in a 0.5% alcohol solution of fuchsin under a pressure of 13800 kN/m² for 24 hours. The broken insulator is taken out and further broken. It should not show any sign of impregnation.

(ix) An impulse over voltage is applied between the pin and the lead foil bound over the top and side grooves in case of pin type and post insulator and between the metal fittings in case of suspension type insulators. The voltage is $1/50 \mu$ sec. wave with amplitude twice the 50% impulse flash overvoltage and negative polarity. Twenty such applications are applied. The procedure is repeated for 2.5, 3, 3.5 times the 50% impulse flash over voltage and continued till the insulator is punctured. The insulator must not puncture if the voltage applied is equal to the one specified in the specification.

(x) The string in insulator is suspended vertically or horizontally and a tensile load 20% in excess of the maximum specified working load is applied for one minute and no damage to the string should occur.

2. What are the different test conducted on cables ? explain any one of them. (CO5-L1-MAY2013)

TESTING OF CABLES

High voltage power cables have proved quite useful especially in case of HV d.c. transmission. Under ground distribution using cables not only adds to the aesthetic looks of a metropolitan city but it provides better environments and more reliable supply to the consumers.

Preparation of Cable Sample

The cable sample has to be carefully prepared for performing various tests especially electrical tests. This is essential to avoid any excessive leakage or end flash overs which otherwise may occur during testing and hence may give wrong information regarding the quality of cables. The length of the sample cable varies between 50 cms to 10 m. The terminations are usually made by shielding the ends of the cable with stress shields so as to relieve the ends from excessive high electrical stresses.

A cable is subjected to following tests:

(i) Bending tests.

(ii) Loading cycle test.

- (iii) Thermal stability test.
- (iv) Dielectric thermal resistance test.
- (v) Life expectancy test.
- (vi) Dielectric power factor test.
- (vii) Power frequency withstand voltage test.
- (viii) Impulse withstand voltage test.
- (ix) Partial discharge test.

(i) It is to be noted that a voltage test should be made before and after a bending test. The cable is bent round a cylinder of specified diameter to make one complete turn. It is then unwound and rewound in the opposite direction. The cycle is to be repeated three times.

(ii) A test loop, consisting of cable and its accessories is subjected to 20 load cycles with a minimum conductor temperature 5°C in excess of the design value and the cable is energized to 1.5 times the working voltage. The cable should not show any sign of damage.

(iii) After test as at (ii), the cable is energized with a voltage 1.5 times the working voltage for a cable of 132 kV rating (the multiplying factor decreases with increases in operating voltage) and the loading current is so adjusted that the temperature of the core of the cable is 5°C higher than its specified permissible temperature. The current should be maintained at this value for six hours.

(iv) The ratio of the temperature difference between the core and sheath of the cable and the heat loss from the cable gives the thermal resistance of the sample of the cable. It should be within the limits specified in the specifications.

(v) In order to estimate life of a cable, an accelerated life test is carried out by subjecting the cable to a voltage stress higher than the normal working stress. It has been observed that the relation between the expected life of the cable in hours and the voltage stress is given by

$$g = \frac{K}{n \sqrt{t}}$$

where K is a constant which depends on material and n is the life index depending again on the material.

(vi) High Voltage Schering Bridge is used to perform dielectric power factor test on the cable sample. The power factor is measured for different values of voltages e.g. 0.5, 1.0, 1.5 and 2.0 Times the rated operating voltages. The maximum value of power factor at normal working voltage does not exceed a specified value (usually 0.01) at a series of temperatures ranging from 15°C to 65°C. The difference in the power factor between rated voltage and 1.5 times the rated voltage and the rated voltage and twice the rated voltage does not exceed a specified value.

Sometimes the source is not able to supply charging current required by the test cable, a suitable choke in series with the test cable helps in tiding over the situation.

(vii) Cables are tested for power frequency a.c. and d.c. voltages. During manufacture the entire cable is passed through a higher voltage test and the rated voltage to check the continuity of the cable. As a routine test the cable is subjected to a voltage 2.5 times the working voltage for 10 min without damaging the insulation of the cable. HV d.c. of 1.8 times the rated d.c. voltage of negative polarity for 30 min. is applied and the cable is said to have withstood the test if no insulation failure takes place.

(viii) The test cable is subjected to 10 positive and 10 negative impulse voltage of magnitude as specified in specification, the cable should withstand 5 applications without any damage. Usually, after the impulse test, the power frequency dielectric power factor test is carried out to ensure that no failure occurred during the impulse test.

(ix) Partial discharge measurement of cables is very important as it gives an indication of expected life of the cable and it gives location of fault, if any, in the cable. When a cable is subjected to high voltage and if there is a void in the cable, the void breaks down and a discharge takes place. As a result, there is a sudden dip in voltage in the form of an impulse. This impulse travels along the cable as explained in detail in Chapter VI. The duration between the normal pulse and the discharge pulse is measured on the oscilloscope and this distance gives the location of the void from the test end of the cable. However, the shape of the pulse gives the nature and intensity of the discharge. In order to scan the entire length of the cable against voids or other imperfections, it is passed through a tube of insulating material filled with distilled water. Four electrodes, two at the end and two in the middle of the tube are arranged. The middle electrodes are located at a stipulated distance and these are energized with high voltage. The two end electrodes and cable conductor are grounded. As the cable is passed between the middle electrode, if a discharge is seen on the oscilloscope, a defect in this part of the cable is stipulated and hence this part of the cable is removed from the rest of the cable.

3. What are the different test conducted on Bushings ? explain in detail (CO5-L1-MAY2013)

TESTING OF BUSHINGS

Bushings are an integral component of high voltage machines. A bushing is used to bring high voltage conductors through the grounded tank or body of the electrical equipment without excessive potential gradients between the conductor and the edge of the hole in the body. The bushing extends into the surface of the oil at one end and the other end is carried above the tank to a height sufficient to prevent breakdown due to surface leakage.

Following tests are carried out on bushings:

(i) Power Factor Test

The bushing is installed as in service or immersed in oil. The high voltage terminal of the bushing is connected to high voltage terminal of the Schering Bridge and the tank or earth portion of the bushing is connected to the detector of the bridge. The capacitance and p.f. of the

bushing is measured at different voltages as specified in the relevant specification and the capacitance and p.f. should be within the range specified.

(ii) Impulse Withstand Test

The bushing is subjected to impulse waves of either polarity and magnitude as specified in the standard specification. Five consecutive full waves of standard wave form ($1/50 \mu \text{ sec.}$) are applied and if two of them cause flash over, the bushing is said to be defective. If only one flash over occurs, ten additional applications are made. If no flash over occurs, bushing is said to have passed the test.

(iii) Chopped Wave and Switching Surge Test

Chopped wave and switching surge of appropriate duration tests are carried out on high voltage bushings. The procedure is identical to the one given in (ii) above.

(iv) Partial Discharge Test

In order to determine whether there is deterioration or not of the insulation used in the bushing, this test is carried out. The procedure is explained in detail in Chapter-VI. The shape of the discharge is an indication of nature and severity of the defect in the bushing. This is considered to be a routine test for high voltage bushings.

(v) Visible Discharge Test at Power Frequency

The test is carried out to ascertain whether the given bushing will give rise to radio interference or not during operation. The test is carried out in a dark room. The voltage as specified is applied to the bushing (IS 2099). No discharge other than that from the grading rings or arcing horns should be visible.

(vi) Power Frequency Flash Over or Puncture Test

(Under Oil): The bushing is either immersed fully in oil or is installed as in service condition. This test is carried out to ascertain that the internal breakdown strength of the bushing is 15% more than the power frequency momentary dry withstand test value.

4. What are the different tests conducted on Power capacitors? explain in detail (CO5-L1-MAY2013)

TESTING OF POWER CAPACITORS

Power capacitors are an integral part of the modern power system. These are used to control the voltage profile of the system. Following tests are carried out on shunt power capacitors (IS 2834):

(i) Routine Tests

Routine tests are carried out on all capacitors at the manufacturer's premises. During testing, the capacitors should not breakdown or behave abnormally or show any visible deterioration.

(ii) Test for Output

Ammeter and Voltmeter can be used to measure the kVAr and capacitance of the capacitor. The kVA rcalculated should not differ by more than -5 to $+10\%$ of the specified value for capacitor units and 0 to 10% for capacitors banks. The a.c. supply used for testing capacitor should have frequency between 40 Hz to 60 Hz, preferably as near as possible to the rated frequency and the harmonics should be minimum.

(iii) Test between Terminals

Every capacitor is subjected to one of the following two tests for 10 secs:

(a) D.C. test; the test voltage being $V_t = 4.3 V_0$

(b) A.C. test $V_t = 2.15 V_0$, where V_0 is the rms value of the voltage between terminals which in the test connection gives the same dielectric stress in the capacitor element as the rated voltage V_n gives in normal service.

(iv) Test between Line Terminals and Container (For capacitor units). An a.c. voltage of value specified in column 2 of Table 5.1 is applied between the terminals (short circuited) of the capacitor unit and its container and is maintained for one minute, no damage to the capacitor should be observed. Figures with single star represent values corresponding to reduced insulation level (Effectively grounded system) and with double star full insulation level (non-effectively grounded system).

(v) IR Test

The insulation resistance of the test capacitor is measured with the help of a megger. The megger is connected between one terminal of the capacitor and the container. The test voltage shall be d.c. volt-age not less than 500 volts and the acceptable value of IR is more than 50 megohms.

(vi) Test for efficiency of Discharge Device

In order to provide safety to personnel who would be working on the capacitors, it is desirable to connect very high resistance across the terminals of the capacitor so that they get discharged in about a few seconds after the supply is switched off. The residual capacitor voltage after the supply voltage is switched off should reduce to 50 volts in less than one minute of the capacitor is rated upto 650 volts and 5 minutes if the capacitor is rated for voltage more than 650 volts. A d.c. voltage $2 \times$ rms rated voltage of the capacitor is applied across the parallel combination of R and C where C is the capacitance of the capacitor under test and R is the high resistance connected across the capacitor. The supply is switched off and the fall in voltage across the capacitor as a function of time is recorded. If C is in microfarads and R in ohms, the time to discharge to 50 volts can be calculated from the formula

$$t = 2.3 \times 10^{-6} CR (\log_{10} V - 1.7) \text{ secs}$$

where V is the rated rms voltage of the capacitor in volts.

Type Tests

The type tests are carried out only once by the manufacturer to prove that the design of capacitor complies with the design requirements:

(i) Dielectric Loss Angle Test (p.f. test)

High voltage schering bridge is used to measure dielectric power factor. The voltage applied is the rated voltage and at temperatures $27^{\circ}\text{C} \pm 2^{\circ}\text{C}$. The value of the loss angle $\tan \delta$ should not be more than 10% the value agreed to between the manufacturer and the purchaser and it should not exceed 0.0035 for mineral oil impregnants and 0.005 for chlorinated impregnants.

(ii) Test for Capacitor Loss

The capacitor loss includes the dielectric loss of the capacitor and the V^2/R loss in the discharge resistance which is permanently connected. The dielectric loss can be evaluated from the loss angle as obtained in the previous test and V^2/R loss can also be calculated. The total power loss should not be more than 10% of the value agreed to between the manufacturer and consumer.

(iii) Stability Test

The capacitor is placed in an enclosure whose temperature is maintained at $\pm 2^{\circ}\text{C}$ above the maximum working temperature for 48 hours. The loss angle is measured after 16 hours, 24 hours and 48 hours using High voltage Schering Bridge at rated frequency and at voltage 1.2 times the rated voltage. If the respective values of loss angle are $\tan \delta_1$, $\tan \delta_2$ and $\tan \delta_3$, these values should satisfy the following relations (anyone of them):

$$(a) \tan \delta_1 + \tan \delta_2 \leq 2 \tan \delta_2 < 2.1 \tan \delta_1$$

$$\text{or (b) } \tan \delta_1 \geq \tan \delta_2 \geq \tan \delta_3$$

(iv) Impulse voltage test between terminal and container

The capacitor is subjected to impulse voltage of $1/50 \mu \text{ sec}$. Five impulses of either polarity should be applied between the terminals (joined together) and the container. It should withstand this voltage without causing any flash overs.

5. Discuss the method of impulse testing of high voltage transformer (or) power Transformer.**TESTING OF POWER TRANSFORMERS**

Transformer is one of the most expensive and important equipment in power system. If it is not suitably designed its failure may cause a lengthy and costly outage. Therefore, it is very important to be cautious while designing its insulation, so that it can withstand transient over voltage both due to switching and lightning. The high voltage testing of transformers is, therefore, very important and would be discussed here. Other tests like temperature rise, short circuit, open circuit etc. are not considered here. However, these can be found in the relevant standard specification.

Partial Discharge Test

The test is carried out on the windings of the transformer to assess the magnitude of discharges. The transformer is connected as a test specimen similar to any other equipment as discussed in Chapter-VI and the discharge measurements are made. The location and severity of fault is ascertained using the travelling wave theory technique as explained in Chapter VI. The measurements are to be made at all the terminals of the transformer and it is estimated that if the apparent measured charge exceeds 104 picocoulombs, the discharge magnitude is considered to be severe and the transformer insulation should be so designed that the discharge measurement should be much below the value of 104 pico-coulombs.

Impulse Testing of Transformer

The impulse level of a transformer is determined by the breakdown voltage of its minor insulation (insulation between turn and between windings), breakdown voltage of its major insulation (insulation between windings and tank) and the flash over voltage of its bushings or a combination of these. The impulse characteristics of internal insulation in a transformer differs from flash over in air in two main respects. Firstly the impulse ratio of the transformer insulation is higher (varies from 2.1 to 2.2) than that of bushing (1.5 for bushings, insulators etc.). Secondly, the impulse breakdown of transformer insulation is practically constant and is independent of time of application of impulse voltage. Fig. shows that after three micro seconds the flash over voltage is substantially constant. The voltage stress between the turns of the same winding and between different windings of the transformer depends upon the steepness of the surge wave front.

The voltage stress may further get aggravated by the piling up action of the wave if the length of the surge wave is large. In fact, due to high steepness of the surge waves, the first few turns of the winding are overstressed and that is why the modern practice is to provide extra insulation to the first few turns of the winding. Fig. shows the equivalent circuit of a transformer winding for impulse voltage.

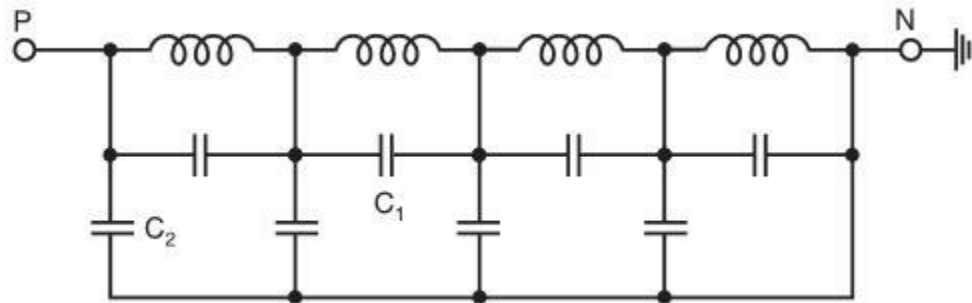

Here C1 represents inter-turn capacitance and C2 capacitance between winding and the ground(tank). In order that the minor insulation will be able to withstand the impulse voltage, the winding is subjected to chopped impulse wave of higher peak voltage than the full wave. This chopped wave is produced by flash over of a rod gap or bushing in parallel with the transformer insulation. The chopping time is usually 3 to 6 micro seconds. While impulse voltage is applied between one phase and ground, high voltages would be induced in the secondary of the transformer. To avoid this, the secondary windings are short-circuited and finally connected to ground. The short circuiting, however, decreases the impedance of the transformer and hence poses problem in adjusting the wave front and wave tail timings of wave. Also, the minimum value of the impulse capacitance required is given by

$$C_0 = \frac{P \times 10^8}{Z \times V^2} \mu\text{F}$$

where P = rated MVA of the transformer Z = per cent impedance of transformer. V = rated voltage of transformer.

Fig. shows the arrangement of the transformer for impulse testing. CRO forms an integral part of the transformer impulse testing circuit. It is required to record to wave forms of the applied voltage and current through the winding under test.

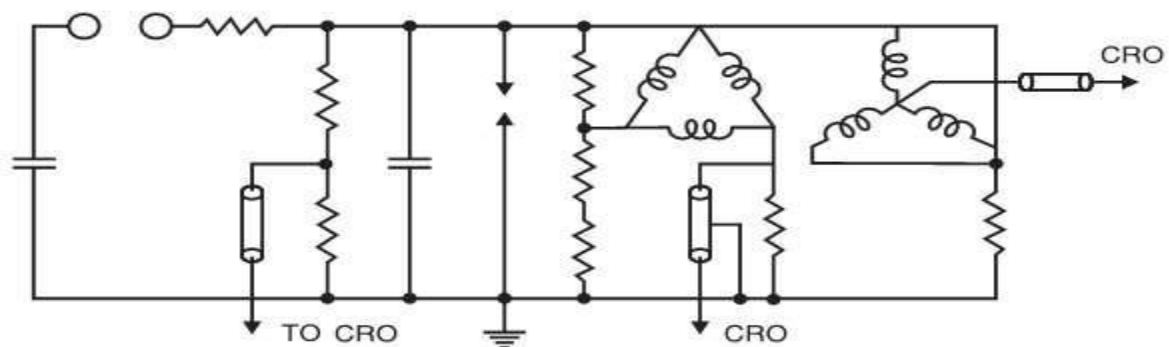

Impulse testing consists of the following steps:

- (i) Application of impulse of magnitude 75% of the Basic Impulse Level (BIL) of the Transformer under test.
- (ii) One full wave of 100% of BIL.
- (iii) Two chopped wave of 115% of BIL.
- (iv) One full wave of 100% BIL and
- (v) One full wave of 75% of BIL.

During impulse testing the fault can be located by general observation like noise in the tank or smoke or bubble in the breather. If there is a fault, it appears on the Oscilloscope as a partial or complete collapse of the applied voltage. Study of the wave form of the neutral current also indicated the type of fault. If an arc occurs between the turns or from turn to the ground, a train of high frequency pulses are seen on the oscilloscope and wave shape of impulse changes. If it is a partial discharge only, high frequency oscillations are observed but no change in wave shape occurs. The bushing forms an important and integral part of transformer insulation. Therefore, its impulse flash over must be carefully investigated. The impulse strength of the transformer winding is same for either polarity of wave whereas the flash over voltage for bushing is different for different polarity. The manufacturer, however, while specifying the impulse strength of the transformer takes into consideration the overall impulse characteristic of the transformer.

6. Discuss the various tests carried out in a circuit breaker at HV lab? (CO5-L1-MAY2013)

TESTING OF CIRCUIT BREAKERS

Equipment when designed to certain specification and is fabricated, needs testing for its performance. The general design is tried and the results of such tests conducted on one selected breaker and are thus applicable to all others of identical construction. These tests are called the type tests. These tests are classified as follows:

1. Short circuit tests:
 - (i) Making capacity test.
 - (ii) Breaking capacity test.
 - (iii) Short time current test.
 - (iv) Operating duty test

2. Dielectric tests:

(i) Power frequency test:

(a) One minute dry withstand test.

(b) One minute wet withstand test.

(ii) Impulse voltage dry withstand test.

3. Thermal test.

4. Mechanical test

Once a particular design is found satisfactory, a large number of similar C.Bs. are manufactured for marketing. Every piece of C.B. is then tested before putting into service. These tests are known as routine tests. With these tests it is possible to find out if incorrect assembly or inferior quality material has been used for a proven design equipment. These tests are classified as

- (i) operation tests,
- (ii) millivolt drop tests,
- (iii) power frequency voltage tests at manufacturer's premises, and
- (iv) power frequency voltage tests after erection on site.

We will discuss first the type tests. In that also we will discuss the short circuit tests after the other three tests.

Dielectric Tests

The general dielectric characteristics of any circuit breaker or switchgear unit depend upon the basic design i.e. clearances, bushing materials, etc. upon correctness and accuracy in assembly and upon the quality of materials used. For a C.B. these factors are checked from the viewpoint of their ability to withstand over voltages at the normal service voltage and abnormal voltages during lightning or other phenomenon.

The test voltage is applied for a period of one minute between

phases with the breaker closed, (ii) phases and earth with C.B. open, and across the terminals with breaker open. With this the breaker must not flash over or puncture. These tests are normally made on indoor switchgear. For such C.Bs the impulse tests generally are unnecessary because it is not exposed to impulse voltage of a very high order. The high frequency switching surges do occur but the effect of these in cable systems used for indoor switchgear are found to be safely withstood by the switchgear if it has withstood the normal frequency test. Since the outdoor switchgear is electrically exposed, they will be subjected to over voltages caused by lightning. The effect of these voltages is much more serious than the power frequency voltages in service. Therefore, this class of switchgear is subjected in addition to power frequency tests, the impulse

voltage tests. The test voltage should be a standard $1/50 \mu$ sec wave, the peak value of which is specified according to the rated voltage of the breaker. A higher impulse voltage is specified for non-effectively grounded system than those for solidly grounded system. The test voltages are applied between (i) each pole and earth in turn with the breaker closed and remaining phases earthed, and (ii) between all terminals on one side of the breaker and all the other terminals earthed, with the breaker open. The specified voltages are withstand values i.e. the breaker should not flash over for 10 applications of the wave. Normally this test is carried out with waves of both the polarities. The wet dielectric test is used for outdoor switchgear. In this, the external insulation is sprayed for two minutes while the rated service voltage is applied; the test overvoltage is then maintained for 30 seconds during which no flash over should occur. The effect of rain on external insulation is partly beneficial, insofar as the surface is thereby cleaned, but is also harmful if the rain contains impurities.

Thermal Tests

These tests are made to check the thermal behaviour of the breakers. In this test the rated current through all three phases of the switchgear is passed continuously for a period long enough to achieve steady state conditions. Temperature readings are obtained by means of thermocouples whose hot junctions are placed in appropriate positions. The temperature rise above ambient, of conductors, must normally not exceed 40°C when the rated normal current is less than 800 amps and 50°C if it is 800amps and above. An additional requirement in the type test is the measurement of the contact resistances between the isolating contacts and between the moving and fixed contacts. These points are generally the main sources of excessive heat generation. The voltage drop across the breaker pole is measured for different values of d.c. current which is a measure of the resistance of current carrying parts and hence that of contacts.

Mechanical Tests

A C.B. must open and close at the correct speed and perform such operations without mechanical failure. The breaker mechanism is, therefore, subjected to a mechanical endurance type test involving repeated opening and closing of the breaker. B.S. 116: 1952 requires 500 such operations without failure and with no adjustment of the mechanism. Some manufacture feel that as many as 20,000 operations may be reached before any useful information regarding the possible causes of failure maybe obtained. A resulting change in the material or dimensions of a particular component may considerably improve the life and efficiency of the mechanism.

Short Circuit Tests

These tests are carried out in short circuit testing stations to prove the ratings of the C.Bs. Before discussing the tests it is proper to discuss about the short circuit testing stations. There are two types of testing stations; (i) field type, and (ii) laboratory type. In case of field type stations the power required for testing is directly taken from a large powersystem. The breaker to be tested is connected to the system. Whereas this method of testing is economical for high voltage C.Bs. it suffers from the following drawbacks:

1. The tests cannot be repeatedly carried out for research and development as it disturbs the whole network.
2. The power available depends upon the location of the testing stations, loading conditions, installed capacity, etc.
3. Test conditions like the desired recovery voltage, the RRRV etc. cannot be achieved conveniently. In case of laboratory testing the power required for testing is provided by specially designed generators. This method has the following advantages:
 1. Test conditions such as current, voltage, power factor, restriking voltages can be controlled accurately.
 2. Several indirect testing methods can be used.
 3. Tests can be repeated and hence research and development over the design is possible. The limitations of this method are the cost and the limited power availability for testing the breakers.

Short Circuit Test Plants

The essential components of a typical test plant are represented in Fig. 5.4. The short-circuit power is supplied by specially designed short-circuit generators driven by induction motors. The magnitude of voltage can be varied by adjusting excitation of the generator or the transformer ratio. A plant master-breaker is available to interrupt the test short circuit current if the test breaker should fail. Initiation of the short circuit may be by the master breaker, but always done by a making switch which is specially designed for closing on very heavy currents but never called upon to break currents. The generator winding may be arranged for either star or delta connection according to the voltage required; by further dividing the winding into two sections which may be connected in series or parallel, a choice of four voltages is available. In addition to this the use of resistors and reactors in series gives a wide range of current and power factors. The generator, transformer and reactors are housed together, usually in the building accommodating the test cells.

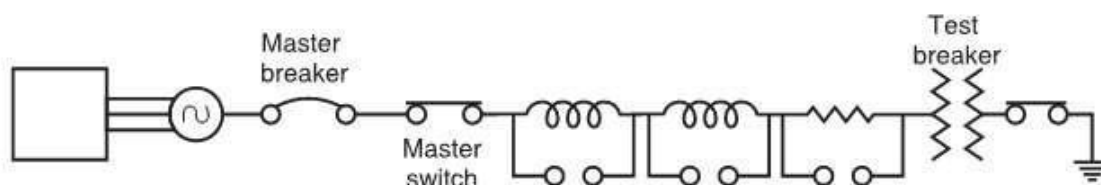

Generator

The short circuit generator is different in design from the conventional power station. The capacity of these generators may be of the order of 2000 MVA and very rigid bracing of the conductors and coil ends is necessary in view of the high electromagnetic forces possible. The limiting factor for the maximum output current is the electromagnetic force. Since the operation of the generator is intermittent, this need not be very efficient.

The reduction of ventilation enables the main flux to be increased and permits the inclusion of extra coil end supports. The machine reactance is reduced to a minimum. Immediately before the actual closing of the making switch the generator driving motor is switched out and the short circuit energy is taken from the kinetic energy of the generator set. This is done to avoid any disturbance to the system during short circuit. However, in this case it is necessary to compensate for the decrement in generator voltage corresponding to the diminishing generator speed during the test. This is achieved by adjusting the generator field excitation to increase at a suitable rate during the short circuit period.

Resistors and Reactors

The resistors are used to control the p.f. of the current and to control the rate of decay of d.c. component of current. There are a number of coils per phase and by combinations of series and parallel connections, desired value of resistance and/or reactance can be obtained.

capacitors

These are used for breaking line charging currents and for controlling the rate of re-striking voltage.

Short Circuit Transformers

The leakage reactance of the transformer is low so as to withstand repeated short circuits. Since they are in use intermittently, they do not pose any cooling problem. For voltage higher than the generated voltages, usually banks of single phase transformers are employed. In the short circuit station at Bhopal there are three single phase units each of 11 kV/76 kV. The normal rating is 30 MVA but their shortcircuit capacity is 475 MVA.

Master C.Bs.

These breakers are provided as back up which will operate, should the breaker under test fail to operate. This breaker is normally air blast type and the capacity is more than the breaker under test. After every test, it isolates the test breaker from the supply and can handle the full short circuit of the testcircuit.

Make Switch

The make switch is closed after other switches are closed. The closing of the switch is fast, sure and without chatter. In order to avoid bouncing and hence welding of contacts, a high air pressure is maintained in the chamber. The closing speed is high so that the contacts are fully closed before the short circuit current reaches its peak value.

Test Procedure

Before the test is performed all the components are adjusted to suitable values so as to obtain desired values of voltage, current, rate of rise of restriking voltage, p.f. etc. The measuring circuits are connected and oscillograph loops are calibrated.

During the test several operations are performed in a sequence in a short time of the order of 0.2 sec. This is done with the help of a drum switch with several pairs of contacts which is rotated with a motor. This drum when rotated closes and opens several control circuits according to a certain sequence. In one of the breaking capacity tests the following sequence was observed:

- (i) After running the motor to a speed the supply is switched off.
- (ii) Impulse excitation is switched on.
- (iii) Master C.B. is closed.
- (iv) Oscillograph is switched on.
- (v) Make switch is closed.
- (vi) C.B. under test is opened.
- (vii) Master C.B. is opened.
- (viii) Exciter circuit is switched off.

The circuit for direct test is shown in Fig. 5.5

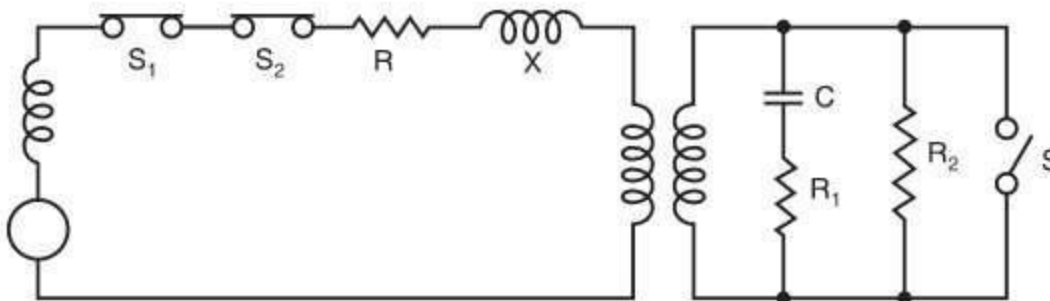

Here XG = generator reactance, S_1 and S_2 are master and make switches respectively. R and X are the resistance and reactance for limiting the current and control of p.f., T is the transformer, C , R_1 and R_2 is the circuit for adjusting the restriking voltage. For testing, breaking capacity of the breaker under test, master and breaker under test are closed first. Short circuit is applied by closing the making switch. The breaker under test is opened at the desired moment and breaking current is determined from the oscillograph as explained earlier. For making capacity test the master and the make switches are closed first and short circuit is applied by closing the breaker under test. The making current is determined from the oscillograph as explained earlier. For short-time current test, the current is passed through the breaker for a short-time say 1 second and the oscillograph is taken as shown in Fig. 5.6. From the oscillogram the equivalent r.m.s. value of short-time current is obtained as follows: The time interval 0 to T is divided into 10 equal parts marked as 0, 1, 2, ..., 9, 10. Let the r.m.s. value of currents at these instants be $I_0, I_1, I_2, \dots, I_9, I_{10}$

(asymmetrical values). From these values, the r.m.s. value of short-time current is calculated using Simpson formula.

